



ACKNOWLEDGEMENT FORM

This is to acknowledge that I have received a copy of the City of Thibodaux Permit Department residential Standard Operating Procedures information package for the proposed or planned residential construction to be performed at the site listed below. I understand that it is my responsibility to provide this information to the individual, owner or contractor that will obtain a permit for the work to be performed at this location. I further understand that the person who obtains the permit shall be responsible to ensure that the construction performed complies with all applicable codes.

Should another copy of the information provided be requested after initial receipt, a duplicate copy fee of \$.50 per sheet shall be payable prior to receipt of this information.

Printed Name

Signature

Permit Address

Date

Please note that this information is also available on the City of Thibodaux's website located at www.ci.thibodaux.la.us. You need to select Public Works Department in white drop down box; then you need to click on Building and Permits section, scroll down until you locate file named Residential Permit Information Package

**CITY OF THIBODAUX
INSPECTION DEPARTMENT
Standard Operating Procedures**

Building permits are required by any owner, authorized agent, or contractor who desires to construct, enlarge, alter, repair, move, demolish or change the occupancy of a building or structure, or to erect, install, enlarge, alter, repair, remove, convert or replace any electrical, gas, or plumbing system, the installation of which is regulated by the technical codes, or to cause any such work to be done, shall first make application to the Building Official and obtain the required permit for the work. **(Refer to Application for Building Permit form attached that must be completed and signed prior to permit issuance.)**

Building permits shall not be required for the following work; however, a Refuse Removal Form will be signed before work is started.

1. Painting, papering, tiling, carpeting, cabinets, counter tops and similar finish work
2. Repair/replace soffit/facial board and the installation of vinyl or aluminum siding
3. Fence repair not to exceed a total of twenty-five (25) linear feet
4. Fences that are less than thirty (30) inches high from natural ground elevation
5. Wood decks not more than thirty (30) inches above grade, with no roof and not over four hundred (400) square feet in floor area
6. Replacing sidewalks and driveways provided there are no alterations or modifications with the location and/or profile of the existing driveway

Demolition Permits

Work must start within thirty (30) days of issuance thereof and be completed within six (6) months or one hundred eighty (180) days from issuance.

Penalty for Missed Inspections

The contractor or homeowner/contractor shall be fined an amount of one hundred dollars (\$100.00) and shall be required to properly execute a "Hold Harmless Agreement" and file a recorded copy of this document with the Lafourche Parish Assessor's office.

Address Numbers Required

As per Chapter 6, Section 6-4 of the City of Thibodaux Code of Ordinances, it is the duty and responsibility of every property owner to have residential, commercial or industrial structures numbered as follows:

- a) Numbering **shall be a minimum of four (4) inches, but sizable so as to be seen from the street / roadway, and shall be displayed on the structure on a background of a contrasting color in a prominent place near an outside light.**
- b) If the entrance of a structure is not visible from the road, addressing numbers shall be located on the front of the building.
- c) On a corner lot, the numbers shall face the street named in the address.
- d) Addressing numbers shall be easily visible at night.
- e) Addressing numbers **shall be plain block numerals**, not script or written numbers.

Lock Box System Required

The Thibodaux Volunteer Fire Department has determined that the health welfare and safety of the citizens of the City of Thibodaux are promoted by requiring certain structures to have a key lock box installed on the exterior of the structure to aid the Fire Department in gaining access to or within a structure when responding to calls for emergency service, and to aid access into or within a building that is secured or is unduly difficult to gain entry due to being either unoccupied or the occupants are unable to respond.

1. The following structures that have monitored alarm systems or sprinkler systems shall be equipped with a key lock box at or near the main entrance or such other location as determined by the Fire Chief.
 - a) Commercial or Industrial Structures.
 - b) Multi-family-residential structures that have restricted access through locked doors but have a common corridor for access to the living units.
 - c) Schools, whether public or private.
 - d) Government structures and nursing care facilities unless the building is staffed or open 24 hours.

2. All new construction and/or remodeling requiring the issuance of a building permit, that have monitored alarm systems or sprinkler systems, shall have a key lock box installed based on the discretion of the Fire Chief. The key lock box shall be operational prior to the issuance of an occupancy permit. All structures in existence on the effective date of this section, that meet the criteria established in item (1) above, shall install a key lock box system within six (6) months.

3. The type of key lock boxes to be implemented within the City of Thibodaux shall be a **Knox Box brand system**.

Installation

1. All Knox Boxes shall be installed to the lock side of the main business door.
2. All Knox Boxes shall be flush or surface mounted approximately five feet from the ground to the center of the entry if possible.
3. In the event that the rapid entry box system cannot be installed at the aforesaid location and/or height the Fire Chief may designate in writing a different location and installation specifications.
4. All realty and/or property with an electronic security gate shall have the Knox Box installed OUTSIDE of the gate.
5. A window decal that is included when the Knox Box is shipped shall be placed on the exterior access door to alert the fire department that a key box is provided.
6. The Fire Chief must approve any changes in the installation.

Maintenance

The operator of the building shall immediately notify the Fire Chief and provide the new keys when a lock is changed or rekeyed. The key to such lock shall be secured in the Knox Box. Operator shall mean the owner of record, tenant, lessee or other person having a possessory or proprietary interest in a commercial building.

Exceptions to requirement to install a key lock box

The following structures are encouraged to, but are exempt from, the mandate to install a key lock box system:

1. Single family structures and multi-family structures that do not meet the definition set forth in (1) (b).
2. Structures that have 24 hour, 365 day on-site security personnel, or have other personnel on site.
3. Businesses that are open and staffed 24 hours, 365 days per year (which may include but are not limited to, nursing homes, hospitals, police stations, etc.).
4. Rental storage facilities where there is a single lock on the separate storage pods that are renter supplied; provided, however, the entry security gates(s) will require a Knox Box if electronically controlled, or locked with a master key issued by the landlord to all tenants.

Contents of lock box

Each lock box on each commercial building shall contain a properly labelled key or keys which will allow access by the fire department to the building, and all rooms or corridors within the building, in the event of an emergency call to that building.

Penalties

Any business or person who violates, neglects, or refuses to comply with any provision of this chapter shall be issued a misdemeanor summons, and upon conviction thereof, be fined not less than \$100 or more than \$750 for each offense, and such person shall be deemed guilty of a separate offense if the key lock box system is not installed within sixty (60) days of conviction.

Permit Issuance Requirements

Prior to permit issuance the following needs to be submitted for plan review:

- 1) Two (2) complete sets of plans consisting of foundation plans, a roof and floor plan including elevation, stairs and landing detail and other details according to plan submittal requirements attached
- 2) Two (2) plot plans showing dimensions and location of structure with all setbacks, servitudes and driveways
- 3) Two (2) plumbing layouts done in red ink to be submitted separate from complete plans; along with fee calculation sheet (copy attached)
- 4) Two (2) electrical layouts in detail showing fixtures and service separate from complete plans; along with fee calculation sheet (copy attached)
- 5) Two (2) gas layouts done in red ink (if applicable) submitted separate from complete plans; along with fee calculation sheet (copy attached)
- 6) Two (2) mechanical layouts, OR Manual D, J, or S, submitted separate from complete plans; along with fee calculation sheet (copy attached)

One plan will be kept on file in the Inspector's Office and one plan will be reviewed and returned to builder and kept on the job at all times for the inspection

OTHER REQUIREMENTS:

1) Proof of bulk disposal container on job site for disposal of all debris generated by the construction or demolition of a structure. The contractor or owner shall have the option of hauling the debris to a state approved landfill or disposal facility. **The contractor or owner shall provide confirmation of an account or agreement existing with the aforesaid landfill before a permit will be issued.**

2) Proof of toilet facilities for workmen on job site must be provided before a permit will be issued.

3) ALL BUILDINGS shall have the floor grade twelve (12) inches above the nearest downstream manhole cover or the surface of the street.

4) Notice to contractors: Please be advised that according to the City of Thibodaux's Code of Ordinances Section 13-1. "Prohibition against excessive noise and time limitations on certain noise producing activities" there is a time limitation on construction and demolition and it is unlawful for any person to operate any equipment used in construction work within a residential area between the hours of 9:00 P.M. and 7:00 A.M. the following day.

5) Stormwater Pollution Prevention Plan (SWPPP)

Beginning January 2, 2017 all residential and commercial construction sites will be required to have a Storm Water Pollution Plan (SWPPP) in place prior to the issuance of any construction approvals or building permit(s). A Stormwater Pollution Prevention Plan (SWPPP) is a site-specific document that is required by the Environmental Protection Agency for construction sites that must comply with stormwater discharge requirements. This plan is more than just a sediment and erosion control plan, but it describes all the activities needed to prevent stormwater contamination and comply with the requirements of the Clean Water Act during construction. During the construction phase of a development project, the SWPPP is the means by which the

city ensures you do not violate the terms of their LDEQ permit. It is the responsibility of the contractor to prepare the SWPPP, implement it onsite, and inspect and maintain the BMPs during the entire construction period.

During site preparation and clearing, the contractor should plan early. Minimizing the area that is disturbed is crucial to preventing stormwater pollution. There is no need to disturb site areas in which construction will not take place. Soil disturbance and unprotected exposure should be minimized and revegetated and mulched as soon as possible. No construction activities should be allowed outside the construction area limits, including the storage of materials and equipment and the parking of construction and workers vehicles.

Sediment Control BMPs should be put in place as to trap or redirect any sediment leaving the site. Sediment control BMPs include silt fences, check dams, drain inlet protection, and sediment retention basins. Examples of standard silt fences and inlet protection using hay bales are shown below. When using the hay bale method for inlet protection the bales shall remain whole and not be broken apart and laid loose along the top of the disturbed soil.

Periodic inspections will be performed by the city's Certified Stormwater Inspector(s) during the construction phase of the project. Any violations of the policy or the city ordinance can and may result in stop work orders being placed on the project until the violations or corrected and up to fine and penalties for extreme and blatant violations.

Should you have any questions regarding this memo please feel free to contact me at (985) 446-7208 or via email at mreulet@ci.thibodaux.la.us.

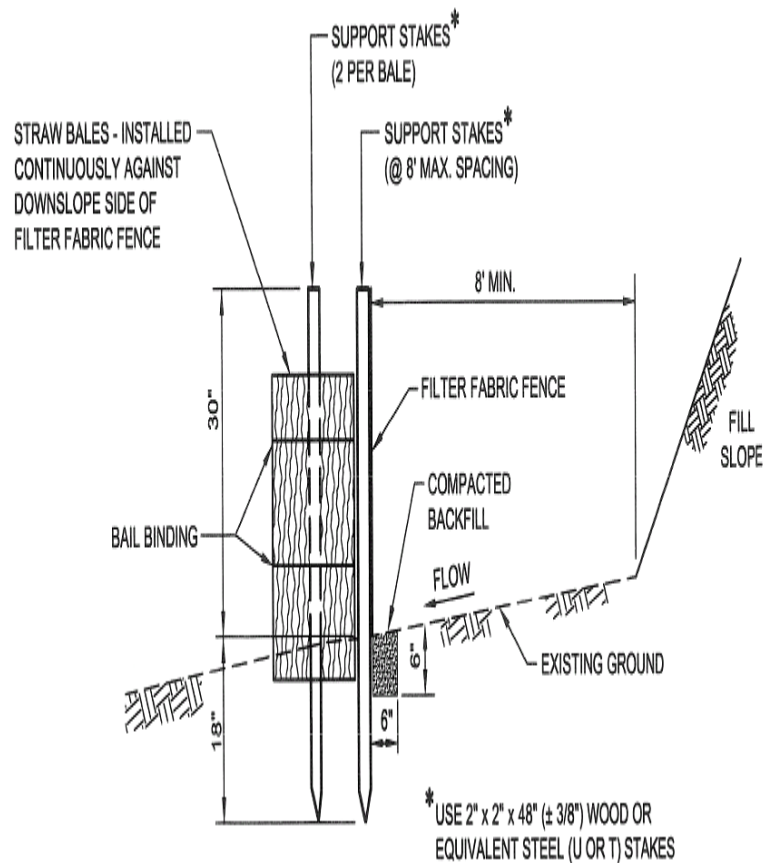
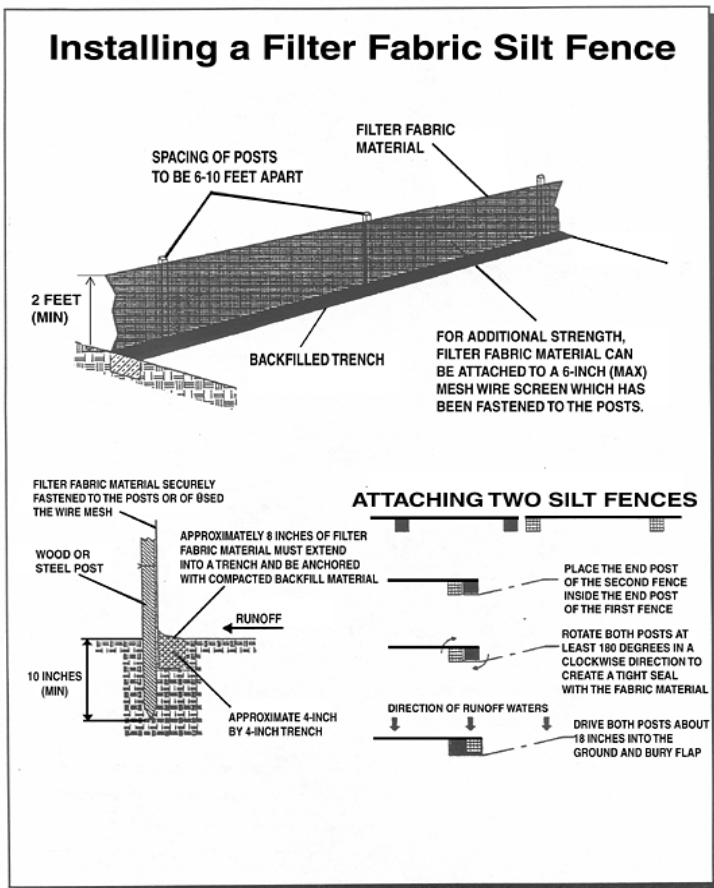

6) Storm Water Discharges – Construction Activities

The contractor/owner/operator shall certify all state requirements have been met by signing a certification statement as part of the building permit application.

1. All operators of construction sites shall use best management practices to control and reduce the discharge, to the City of Thibodaux, MS4, and to waters of the United States, of sediment, silt, earth, soil and other material associated with the clearing, grading, excavation, and other construction activities to the maximum extent practicable. Such best management practices may include, but not be limited to, the following measures:
 - (a) Ensuring that existing vegetation is preserved where feasible and that disturbed portions of the site are stabilized as soon as practicable in portions of the site where construction activities have temporarily or permanently ceased. Stabilization measures may include: temporary seeding, permanent seeding, mulching, geotextiles, sod stabilization, vegetative buffer strips, protection of trees, preservation of mature vegetation and other appropriate measures;
 - (b) Use of structural practices to divert flows from exposed soils, store flows, or otherwise limit runoff and the discharge of pollutants from the site to the extent feasible;
 - (c) Minimization of the tracking of sediments off-site by vehicles, the generation of dust, and the escape of other windblown waste from the site;
 - (d) Prevention of the discharge of building materials, including cement, lime, concrete and mortar to the City, MS4 or waters of the United States;
 - (e) Providing general good housekeeping measures to prevent and contain spills of paints, solvents, fuels, septic waste and other hazardous chemicals and pollutants associated with construction, and to assure proper clean and disposal of any such spills in compliance with state, federal and local requirements;
 - (f) Implementation of proper waste disposal and waste management techniques, including covering waste materials and minimizing ground contact with hazardous chemicals and trash;
 - (g) Timely maintenance of vegetation, erosion and sediment control measures and other best management practices in good and effective operating condition; and
 - (h) Installation of structural measures during the construction process to control pollutants in storm water discharges that will occur after construction operations have been completed. Structural measures should be placed on upland soils to the degree attainable. Such installed structural measures may include, but not be limited to the following: storm water detention structures (including wet ponds); flow attenuation by use of open vegetative swales and natural depressions; other velocity dissipation devices, infiltration of runoff on site; and sequential systems which combine several practices. Operators of construction sites are only responsible for the installation and maintenance of storm water management measures prior to final stabilization of the site and are not responsible for maintenance after storm water discharges associated with construction activity have terminated.
2. Personnel (provided by the operator of the construction site) shall inspect disturbed areas of any construction site (meeting criteria of current NPDES permit) that have not been finally stabilized, areas used for storage of materials that are exposed to precipitation, structural control measures and locations where vehicles enter or exit the site in accordance with the current NPDES permit. All erosion and sediment control measures and other identified best management practices shall be observed in order to ensure that they are operating correctly and are effective in preventing significant impacts to receiving waters, the City and the MS4. Based on the results of the inspections, best management practices shall be revised as appropriate and as soon as is practicable.

3. The city may require any plans and specifications that are prepared for the construction of site improvement to illustrate and describe the best management practices required by subsection (1) (a) above that will be implemented at the construction site. The city may deny approval of any building permit, site development plan, or any other city approval necessary to commence or continue construction, or to assume occupancy, on the grounds that the management practices described in the plans or observed upon the site inspection by the city are determined not to control and reduce the discharge of sediment, silt, earth, soil and other materials associated with clearing, grading, excavation, and other construction activities to the maximum extent practicable.
4. Any owner of a site of construction activity, whether or not he/she is an operator, is jointly and severally responsible for compliance with the requirements in this section.
5. Any contractor or subcontractor on a site of construction activity, who is not an owner or operator, but who is responsible under his/her contract or subcontract for implementing best management practices control measure, is jointly and severally responsible for any willful or negligent failure on his/her part to adequately implement that control measure if such failure causes or contributes to causing the city to violate a water quality standard, the city's NPDES permit, or any state-issued discharge permit for discharges from its MS4.
6. Based on the results of the inspections required by subsection (2), the site description and/or the pollution prevention measures shall be revised as appropriate, but in no case later than one (1) calendar day following the inspection. Such modifications shall provide for the timely implementation of any changes to the SWPPP within one (1) calendar day following the inspection.
7. Upon final stabilization of the construction site, the owner of the duly authorized representative thereof shall submit written certification to the city that the site has been finally stabilized. The city may withhold an occupancy or use permit for any premises constructed on the site until certification of final stabilization has been filed and the city has determined, following any appropriate inspection, that final stabilization has, in fact, occurred and that any required permanent structural controls have been completed.
8. Construction activity, including clearing, grading and excavation activities, that result in the disturbance of one (1) or more acres of total land area shall comply with the requirements of this chapter. This also applies to building construction (including commercial and residential) on lots less than (1) acre.

(Ord. 2368, 12-18-07)

CITY OF THIBODAUX

Building Code Requirements

Building codes:

Residential construction — 2021 International Residential Code

Commercial construction— 2021 International Building Code

2021 International Existing Building Code

*Option of

Choosing one
or more

* ICC 600-2014 Standard for Residential Construction in High Wind Regions

* 2015 Wood Frame Construction Manual for 1 & 2 Family Dwellings

Electrical codes:

2020 National Electrical Code

2018 Entergy Customer Installation Standards

Plumbing codes:

2021 International Plumbing Code

Gas code:

2021 International Fuel Gas Code

Mechanical code:

2021 International Mechanical Code

ADA:

American National Standard – Accessible & Usable Buildings & Facilities

PLAN SUBMITTAL REQUIREMENTS

Governing Codes

Building
Electrical
Mechanical
Plumbing
Gas
Basic wind speed
Occupancy Classification
Occupancy Type

Site Plan

Owner or Contractor Name
Lot and block number
Street address
Lot description
Setbacks
Width and length of Parking Spaces & Aisles

Floor Plan

Square footage of living
Square footage of non-living
Door and window schedule
Ceiling height
Location of smoke alarms

Roof Plan

Roof layout
Roof pitch
Ridge cap detail

Elevations

Front
Right side
Left side
Rear

Foundation Plan

Exterior grade beams
Interior grade beams
Anchor bolts for bottom plate
Shear wall hold downs

Framing Plan

Exterior wall sections
Cross sections of building
Bracing of attic
Gable end wall
Ceiling joist framing
Shear wall sheathing panel bracing
Location of shear walls
Profile of columns/post anchoring
Type & location of hurricane straps
Note on how glazing will be protected
DP rating for windows

Plumbing Plan

Plumbing site
Plumbing below slab
Plumbing isometrics
Plumbing above slab

Electrical Plan

Electrical site plan
Power floor plan
Lighting floor plan
Electrical riser diagram
Panel board schedule
Panel location and size
Label circuits

Mechanical Plan

Mechanical floor plan
Equipment layout (sizes)
Duct work layout (sizes)

CITY OF THIBODAUX

Permit Fee Rates

COMMERCIAL CONSTRUCTION PERMIT FEES

\$100,000.00 and less.....Fee = \$ 3.00 / thousand
\$101,000.00 to \$500,000.00Fee = \$ 300.00 + \$2.00 / \$1,000 above \$100,000.00
\$501,000.00 and overFee = \$1,100.00 + \$1.50 / \$1,000 above \$500,000.00

RESIDENTIAL CONSTRUCTION PERMIT FEES

\$100,000.00 and less.....Fee = \$ 2.50 / thousand
\$101,000.00 to \$500,000.00Fee = \$ 250.00 + \$2.00 / \$1,000 above \$100,000.00
\$501,000.00 and overFee = \$1,050.00 + \$1.50 / \$1,000 above \$500,000.00

OTHER STRUCTURES (Including but not limited to): Swimming pools, renovations, open porches and canopies, fire damage, shell buildings, etc.
Fee = \$3.00 / thousand

Minimum Permit FeeFee = \$40.00 (applies to commercial & residential)

OTHER PERMIT FEES / AMOUNTS

DemolitionFee = \$50.00
Driveway Curb-CutFee = \$10.00
90 Day ExtensionFee = \$20.00
Re-inspection.....Fee = \$50.00

SIGN PERMIT FEES

1 to 25 sq. feetFee = \$ 25.00
26 to 99 sq. feetFee = \$ 50.00
100 + sq. feet.....Fee = \$100.00+\$1.50 / sq.ft. over

ZONING PERMIT FEES

Fence Fee = \$23.00
Manufactured Home Relocation Fee = \$40.00
Home Relocation (owner) Fee = \$40.00
Home Relocation (mover)..... Fee = \$100.00
Occupancy / Building Fee = \$40.00
Occupancy / Zoning..... Fee = \$23.00
Telephone/Mail Use Fee = \$23.00
Variance Application Fee = \$30.00

All fees must be paid by check, money order or Visa/Mastercard prior to permit issuance.

Any work performed without permit issuance is subject to double fees.

CITY OF THIBODAUX

Inspection Requirements

Building inspection shall be performed in the foundation, framing and completion stages

Electrical inspection shall be performed in the foundation, rough-in and completion stages

Plumbing inspection shall be performed in the foundation, rough-in and completion stages

Gas inspection shall be performed in the rough-in and completion stages

Mechanical inspection shall be performed in the rough-in and completion stages

Any additional inspections that may be required

**Phone number to call for Building, Electrical, Plumbing, Gas & Mechanical Inspections:
985-446-7208 or 985-446-7205**

Request(s) for inspection must be made by the respective building contractor, electrician and plumber performing the work at the job site. **Contractors have to allow the inspection department up to forty-eight (48) hours to perform inspections from the time the inspection request is received.**

Permit Cards

No inspections shall be performed without the permit being displayed on the job site.

The permit holder shall post the permit on the job site where they are visible from the road. The permit shall be maintained by the permit holder until the final inspection has been made and approved.

Re-inspection fee of fifty dollars (\$50.00) may be charged for any additional inspections required after any of the initial free inspections referenced above.

Certificate of Occupancy

A certificate of occupancy will be issued upon completion of all inspections and the payment of all cost associated with the inspections have been paid in full. **No one shall be allowed to furnish or move in until certificate of occupancy has been issued.**

Zoning Compliance Certificate

A certificate of zoning compliance will be issued upon completion of all inspections and the payment of all cost associated with the inspections have been paid in full. **No one shall be allowed to furnish or move in until certificate of zoning compliance has been issued.**

CITY OF THIBODAUX
REGISTRATION REQUIREMENTS - Electricians

Electrical Registration Requirements

All electrical work to be performed within the City limits shall be performed by a City registered electrician. In order to obtain a City electrical registration, contractor shall be required to furnish the Inspection Department with a copy of their State electrical license. If contractor is not licensed state-wide, they have the option to take an electrical examination administered quarterly by the Inspection Department. Electrical examinations are typically scheduled in the months of January, April, July and October on the 1ST Wednesday of the month.

In addition, electrical contractor shall be required to furnish the Inspection Department with a \$2,000.00 contractor's or performance bond and liability insurance in the amount of \$20,000 as required by City ordinance.

These items may be furnished to the Inspection Department by either fax, email, mail or at office.

Email Address: mreulet@ci.thibodaux.la.us or scabrera@ci.thibodaux.la.us

Physical Address: **1219 Henry S. Thibodaux Street, Thibodaux, LA**

Mailing Address: **City of Thibodaux, Inspection Dept., P. O. Box 5418, Thibodaux, LA 70302**

Once the Inspection Department is in receipt of these items, a release form shall be forwarded to the "Tax and License Department." Contractor should contact Tax & License Department at (985) 446-7221 for further information regarding obtaining a City electrical license.

NOTE: Homeowners do have the right to perform their own electrical work provided they are knowledgeable of the electrical code requirements. **However, should the electrical work that is performed by the homeowner demonstrate that they do not know the applicable code requirements, they shall be required to obtain a City registered electrician. All work performed is subject to and shall be inspected.**

ELECTRICAL PERMIT FEE CALCULATION SHEET

Thibodaux, Louisiana

Phone: (985) 446-7208

Electrician's Name & Mailing Address:

┌ _____ ┐

└ _____ ┘

Date: _____

Property Owner: _____

Project Address: _____

Entergy Acct #: _____

Name on Acct: _____

Description

FEEES ASSOCIATED WITH ABOVE ELECTRICAL INSTALLATION

- Entergy Service Inspection _____
- Main electrical service Amperage of Service _____
- Main panels Amperage of Panels _____
- Automatic Transfer Switch Amperage of ATS..... _____
- Square ft. living (inspection) _____
- Square ft. other (inspection) _____
- Temporary electrical service.....Number of Services..... _____
- Air Conditioner Systems Amperage of units..... _____
-
- Square ft. living (plan review) _____
- Square ft. other (plan review) _____
- Parking lot lighting.....Number of Lights..... _____
- Other: _____
- _____
- _____

TOTAL ELECTRICAL VALUE: \$ _____

SIGNATURE VERIFICATION: _____

**All fees must be paid by check, money order or Visa/Mastercard/Discover prior to permit issuance.
*** Any work performed without permit issuance is subject to double fees.*****

CITY OF THIBODAUX
REGISTRATION REQUIREMENTS - Plumbers

Plumbing Registration Requirements

All plumbing work to be performed within the City limits shall be performed by a City registered plumber. In order to obtain a City plumbing registration, contractor shall be required to furnish the Inspection Department with a copy of their State plumbing license.

In addition, plumbing contractor shall be required to furnish the Inspection Department with a \$5,000.00 contractor's or performance bond as required by City ordinance.

These items may be furnished to the Inspection Department by either fax, email, mail or at office.

Email Address: mreulet@ci.thibodaux.la.us or scabrera@ci.thibodaux.la.us

Physical Address: **1219 Henry S. Thibodaux Street, Thibodaux, LA**

Mailing Address: **City of Thibodaux, Inspection Dept., P.O. Box 5418, Thibodaux, LA 70302**

Once the Inspection Department is in receipt of these items, a release form shall be faxed to the "Tax and License Department." Contractor should contact Tax & License Department at (985) 446-7221 for further information regarding obtaining a City plumbing license.

NOTE: Homeowners do have the right to perform their own plumbing work provided they are knowledgeable of the plumbing code requirements. However, should the plumbing work that is performed by the homeowner demonstrate that they do not know the applicable code requirements, they shall be required to obtain a City registered plumber. All work performed is subject to and shall be inspected.



City of Thibodaux
City Inspector's Office
P.O. Box 5418
Thibodaux, Louisiana 70302

Phone: 985-446-7208

PLUMBING FEE CALCULATION SHEET

Plumber's Name & Mailing Address:

Property Owner: _____

Address: _____

Date: _____

Description

FIXTURES ASSOCIATED WITH ABOVE PLUMBING INSTALLATION

- Water Closets (6.00) _____
- Tubs (6.00) _____
- Shower (6.00) _____
- Lavatories (6.00) _____
- Sinks (6.00) _____
- Clothes Washer (6.00) _____
- Dish Washer (6.00) _____
- Floor Drains (6.00) _____
- A/C Drains..... (6.00) _____
- Water Heater..... (6.00) _____
- Water Service (8.00) _____
- Lawn & Roof Sprinklers (8.00) _____
- Vacuum Breaker (8.00) _____
- Drinking Fountains (6.00) _____
- Urinals (6.00) _____
- Rough In..... (32.00) _____
- Sewer Tie In..... (32.00) _____
- Sewer Service (48.00) _____
- Sewer Extension (32.00) _____
- Re-inspection Fee..... (50.00) _____
- Other _____

All fees must be paid by check, money order or Visa/Mastercard prior to permit issuance.
Any work performed without permit issuance is subject to double fees.

SIGNATURE VERIFICATION: _____

CITY OF THIBODAUX
REGISTRATION REQUIREMENTS
Mechanical Contractors

Mechanical Registration Requirements

All mechanical work to be performed within the City limits shall be performed by a City registered mechanical contractor. In order to obtain a City mechanical registration, contractor shall be required to furnish the Inspection Department with a copy of their State mechanical or State plumbing license.

In addition, mechanical contractor shall be required to furnish the Inspection Department with a \$5,000.00 contractor's surety or performance bond and liability insurance in the amount of \$100,000 as required by City ordinance.

These items may be furnished to the Inspection Department by either fax, email, mail or at our office.

Email Address: mreulet@ci.thibodaux.la.us or scabrera@ci.thibodaux.la.us

Physical Address: 1219 Henry S. Thibodaux Street, Thibodaux, LA

Mailing Address: City of Thibodaux, Inspection Dept., P.O. Box 5418, Thibodaux, LA 70302

Once the Inspection Department is in receipt of these items, a release form shall be forwarded to the "Tax and License Department." Contractor should contact Tax & License Department at (985) 446-7221 for further information regarding obtaining a City mechanical license.

NOTE: Homeowners do have the right to perform their own mechanical work provided they are knowledgeable of the mechanical code requirements. **However, should the mechanical work that is performed by the homeowner demonstrate that they do not know the applicable code requirements, they shall be required to obtain a City registered mechanical contractor. All work performed is subject to and shall be inspected.**



PERMIT APPLICATION FORM
Residential Mechanical
CITY OF THIBODAUX
P. O. Box 5418
Thibodaux, LA 70302

PH: 985-446-7208

Contractor's Name & Mailing Address:

DATE: _____

┌ _____ ┐

 └ _____ ┘

Property Owner: _____

Address: _____

These fees will have application to all types of mechanical installations, inside and outside the main structure on the same parcel of property. These fees apply to residential dwelling units or structures.

<i>CODE</i>	<i>ITEM</i>	<i>QUANTITY</i>	<i>PRICE</i>
M01	Installation of complete A/C system in new construction	05 x _____ Sq.Ft. =	_____
M02	Change out complete A/C equipment in existing structures	_____	65.00
M03	Change out. heater only	_____	31.00
M04	Change out. condenser only	_____	31.00
M05	Permit re-instatement	_____	40.00
M06	Minimum fee	_____	25.00
M07	Duct alteration	_____	31.00
M08	Plan Review	.01 x _____ Sq.Ft. =	_____

TOTAL MECHANICAL VALUE: \$ _____

SIGNATURE VERIFICATION: _____

All fees must be paid by check, money order or Visa/Mastercard prior to permit issuance. Any work performed without permit issuance is subject to double fees.

CITY OF THIBODAUX

GAS INSPECTION INFORMATION

Plan Review

The customer or plumber is required to submit two sets of plans showing the proposed location of new gas piping drawn in red. The size of the pipe, location of isolation valves and the number of fixtures to be served with gas must also be marked on the plans. These plans must be accompanied with a Fixtures Sheet which includes the plumbers name, mailing address, license number, owner's name, address and date of submittal. A list of fixtures associated with natural gas and BTU demand must also be provided at the same time. Both sets are reviewed for compliance with all codes and City ordinances, changes are noted on the plans, stamped, signed and dated. One set remains in the office of the Gas Superintendent and the other returned to the customer or plumber who submitted the plans to follow during pipe installation.

INSPECTIONS REQUIRED

Gas Open Wall Inspection

After the gas piping is installed according to the plans approved and piping ready for inspection, the plumber must contact the Permits Division of Public Works at 446-7208 to request a gas open wall inspection. The inspection will be conducted within two working days of the request. The plumber will be contacted to inform them of the results of the inspection as well as to inform them of any violations discovered.

Gas Pipe Pressure Test

After passing the gas open wall inspection, the gas piping must be tested to assure that there are no leaks. The test will be a minimum of 16 oz. and hold for 15 minutes with no loss of pressure. Test pressure shall be measured with a manometer or with a pressure-measuring device designed and calibrated to read, record or indicate a pressure loss caused by leakage during the pressure test period. The source of pressure shall be isolated before the pressure tests are made. Mechanical gauges used to measure test pressures shall have a range such that the highest end of the scale is not greater than five times the test pressure. The plumber must contact the Permits Division of Public Works at 446-7208 to request a gas pressure test for customer piping. The inspection will be conducted within two working days of the request. The plumber will be contacted to inform them of the results of the test.

Gas Final Inspection

After passing inspections for both the gas open wall and gas pipe pressure test and all related costs have been paid, the Gas and Water Division of Public Works will install the gas meter and gas regulator to serve the structure. The customer's plumber must then connect the customer's pipe to the outlet side of the gas meter and install a test tee with 1/4" outlet and plug on the downstream side of the gas meter. The customer's plumber must then connect and test all gas fixtures for leaks and repair before calling the Permits Division to request a gas final inspection. The inspection will be conducted within two working days of the request if entry is possible.

NOTE: All work done on gas piping in the City of Thibodaux must be done by a registered plumber or mechanical contractor, inspected and documented before gas service will be activated.

GENERATOR INSTALL PERMIT INFORMATION SHEET

Thibodaux, Louisiana

Phone: (985) 446-7208

1. City - Registered Electrician must pull permit for Electrical portion of project. They must provide:

-Amperage of Service (If Replacing or Upgrading)

-Amperage of Transfer Switch (Under "Panels")

* The panel/service must pass inspection prior to the reconnect order being issued to Entergy.

2. City - Registered Plumber OR Mechanical Contractor must pull permit for Gas portion of project. They must provide:

-List of all existing gas fixtures, and the BTU's for each.

-The BTU's of the new fixture (Generator)

* A pressure test must be completed and passed prior to a gas meter being installed and project being completed.



City of Thibodaux
P.O. Box 5418
Thibodaux, Louisiana 70302

Gas & Water- 985-446-7216
Permits- 985-446-7208

GAS PERMIT FEE CALCULATION SHEET

Plumber's Name & Mailing Address:

Form with three horizontal lines for address and corner brackets.

Property Owner:

Address:

Date:

Description

Please provide fixtures associated with above natural gas installation and/or existing fixtures.

Label each fixture as Existing (E) or New (N)

EQUIPMENT DESCRIPTION

Table with columns: EQUIPMENT DESCRIPTION, TOTAL BTU'S, QUANTITY, BTU's. Rows include Gas Meter Loop & Gas Piping System Test, Central Heat, Water Heater, Clothes Dryer, Kitchen Stove, Fireplace, Gas Lights, Generator, Other, and Other.

All fees must be paid by check, money order or Visa/Mastercard prior to permit issuance.
Any work performed without permit issuance is subject to double fees.

SIGNATURE VERIFICATION:

NOTE: The following information is provided only as a general guideline and is certainly not intended to encompass all of the adopted building code requirements.

Building Inspection Procedures:

The following items shall be checked in the foundation stage:

- 1) Site preparation
- 2) Elevation of foundation
- 3) Fill in foundation
- 4) Reinforcement support
- 5) Protection against termites
- 6) Vapor retarder
- 7) Location of rebar and corner bars for uplift resistance
- 8) Depth of footings
- 9) Clean footings
- 10) Wall to foundation anchorage hold downs
- 11) Columns restrained – if required

The following items shall be checked in the rough-in stage:

- 1) Wall to foundation anchorage (bolts)
- 2) Fasteners
- 3) Ceiling height of exterior walls
- 4) Minimum opening area
- 5) Glazing – hazardous locations
- 6) Headers
- 7) Drilling and notching
- 8) Fire blocking required
- 9) Floor, ceiling and rafter spans
- 10) Beams
- 11) Bracing in attic
- 12) Gable end walls
- 13) Columns restrained – if installed
- 14) Shearwalls
- 15) High wind tie downs
- 16) Roof sheathing (fastener)
- 17) Stairs
- 18) Two-family dwelling unit separation

The following items shall be checked in the final stage:

- 1) Protection of openings
- 2) Numbering on house
- 3) Smoke detectors
- 4) Combustible – penetration
- 5) Fire place – hearth – ext. – materials
- 6) Columns
- 7) Shower door glazing
- 8) Attic access
- 9) Railing for stairs – landing
- 10) Drainage

Plumbing Inspection Procedures:

Permit Required

- 1) Review plan
- 2) Quote inspection fees
- 3) Verify license and bond

Four Inspections Required

1) Rough in slab

- a. Sign requirements
- b. Toilet facilities
- c. Pressure test for sewer and water lines
- d. Supporting of piping
- e. Location and sizing of vent lines
- f. Installation of piping and fittings
- g. Elevation of plumbing accordance to sewer man hole

2) Open wall

- a. Sign requirements
- b. Pressure test for sewer and water lines
- c. Supporting of piping
- d. Location of clean outs
- e. Installation of piping and fittings
- f. Protection of piping in walls
- g. Installation of mechanical vents
- h. Water service
- i. Location of water heaters in attic and closets

3) Sewer tie-ins

- a. Sign requirements
- b. Size and location of clean outs
- c. Installation of piping and fittings

4) Final

- a. Valve box and clean out covers
- b. Discharge of relief valve
- c. Shut off valves and trap for each fixture
- d. Sizing of fixture supply lines and trap
- e. Clearance of mechanical vents from all combustible material
- f. Installation of plumbing fixtures

Electrical Inspection Procedures:

Permit Required

- 1) Review plan
- 2) Quote inspection fees
- 3) Verify license and bond

Four Inspections Required

1) Temporary service

- a. Size and height of pole
- b. Height of pull point & meter pan
- c. Installation of meter pan, wiring and grounding
- d. Strapping and bracing of service
- e. GFCI receptacles or breakers
- f. Apply all of Entergy's standards

2) Rough in wiring

- a. Staple or support of wiring
- b. Protection of wiring
- c. Cubic inches
- d. Location of service
- e. Installation of panel, boxes and wiring
- f. Required circuits in residential homes

3) Permanent service

- a. Height of pull point and meter pan
- b. Location of main breaker
- c. Grounding of service
- d. Size of conductors and conduit
- e. Clearance for windows, doors and gas meter
- f. Installation of conduit and pull string

4) Final

- a. Label panel
- b. GFCI
- c. Light and receptacle in attic
- d. Bonding of gas line, water line and service
- e. Location of receptacles
- f. Four plug receptacle for dryer and stove

Mechanical Inspection Procedures:

Permit Required

- 1) Review plan
- 2) Quote inspection fees

Two Inspections Required

1) Rough In

- a. Label information on equipment
- b. Equipment and appliance location
- c. Clearances
- d. Walkway and service space
- e. Venting
- f. Cutting, notching and boring

2) Final

- a. Label information on equipment
- b. Clearance around equipment
- c. Exhaust hoods and vents
- d. Check return air
- e. Thermostat location
- f. Check for hot or cold spots

NEW CONSTRUCTION BUILDING PERMIT APPLICATION

Thibodaux, Louisiana

Phone: (985) 446-7208

The undersigned applies for a building permit for the following use, said permit to be issued on the basis of the information contained within this application. The applicant hereby certifies that all information and attachments to this application are true and correct. The applicant is required, in addition to the information requested on this form to submit plans, in duplicate and drawn to scale, showing the actual dimensions and shape of the lot, exact sizes and locations of existing buildings on the lot, and the location and dimensions of the proposed buildings or alterations.

1. **Locational Description:** Subdivision Name _____

Block: _____ Lot: _____

Building Address: _____

2. **Name of Owner:** _____

Mailing Address: _____

Phone No.(s): Home: _____ Work: _____ Cell: _____

3. **Name of Contractor:** _____

Mailing Address: _____

Phone No.(s): Office: _____ Cell: _____ Contact: _____

4. **Proposed Use:**

Select One (1): Residential _____ Commercial _____ Industrial _____

Select Type of New Construction: Principal Building: _____ Accessory Building _____

Residence _____ # of Units _____ Other (Explain) _____

(If proposed site is commercial or industrial furnish description of the nature of the business or industry.)

5. Lot Area: _____ Percentage of lot to be occupied: _____ %

6. Lot Width: _____ Lot Depth: _____

7. Square Feet of Project – Area Residential (Living): _____

Commercial: _____ Industrial: _____

8. Building Height: Stories: _____ Feet: _____

9. Yard Dimensions: Front: _____ Rear: _____

One Side: _____ Sum of Side Yards: _____

10. Accessory Building Dimensions: Height: _____ Size / Dimensions: _____

11. Number of off-street parking spaces to be provided: _____
12. Number of off-street loading berths to be provided: _____
13. On a separate sheet attach a list of other supplemental requirements or conditions that will be met, or explain any points you feel need clarification.
14. **Estimated Project Cost:** _____

NOTE: This permit shall be void if work is not started within six (6) months or completed within 2 years.

Printed Name: _____

Signature: _____

Date: _____

(For Official Use Only)

Date Application Received: _____

Fee Paid: _____

Date of Action on Application: _____

Approved _____ Denied _____

If application denied, reason(s) for denial:

Zoning Administrator

RENOVATION/ADDITION BUILDING PERMIT APPLICATION

Thibodaux, Louisiana

Phone: (985) 446-7208

The undersigned applies for a building permit for the following use, said permit to be issued on the basis of the information contained within this application. The applicant hereby certifies that all information and attachments to this application are true and correct. The applicant is required, in addition to the information requested on this form to submit plans, in duplicate and drawn to scale, showing the actual dimensions and shape of the lot, exact sizes and locations of existing buildings on the lot, and the location and dimensions of the proposed buildings or alterations.

CHECKLIST:

- Permit Fee
- Site Plan
- Completed Application

1. **Building Address:** _____

2. **Name of Owner:** _____

Mailing Address: _____

Phone No.(s): Home: _____ Work: _____ Cell: _____

3. **Name of Contractor:** _____

Mailing Address: _____

Phone No.(s): Office: _____ Cell: _____ Contact: _____

4. **Proposed Use:**

Select One (1):

Residential _____ Commercial _____ Industrial _____

Select Project Type:

Alteration/Addition _____ Accessory Building _____ Re-roofing _____

Other (Explain) _____

5. Lot Area: _____ Percentage of lot to be occupied: _____ %

6. Lot Width: _____ Lot Depth: _____

7. **Square Feet of Project Area**

Residential (Living): _____ Commercial: _____ Industrial: _____

8. Yard Dimensions: Front: _____ Rear: _____
One Side: _____ Sum of Side Yards: _____

9. Dimensions of Addition: Height: _____ Size/Dimensions: _____

10. **Estimated Project Cost:** _____

NOTE: This permit shall be void if work is not started within six (6) months or completed within 2 years.

Printed Name: _____

Signature: _____

Date: _____

DEMOLITION PERMIT APPLICATION

Thibodaux, Louisiana

Phone: (985) 446-7208

The undersigned applies for a building permit for the following use, said permit to be issued on the basis of the information contained within this application. The applicant hereby certifies that all information and attachments to this application are true and correct. The applicant is required, in addition to the information requested on this form to submit plans, in duplicate and drawn to scale, showing the actual dimensions and shape of the lot, exact sizes and locations of existing buildings on the lot, and the location and dimensions of the proposed buildings or alterations.

CHECKLIST:

- Permit Fee
- Completed Application

1. Building Address: _____

2. Name of Owner: _____

Mailing Address: _____

Phone No.(s): Home: _____ Work: _____ Cell: _____

3. Name of Contractor: _____

Mailing Address: _____

Phone No.(s): Office: _____ Cell: _____ Contact: _____

4. Property Type:

Select One (1):

Residential _____ Commercial _____ Industrial _____

5. Select Demolition Type:

Partial Demolition _____ Complete Demolition _____

**If partial demolition, please provide plans indicating scope of work/work area. **

6. Estimated Project Cost: _____

NOTE: This permit shall be void if work is not started within six (6) months or completed within 2 years.

PERMIT IS ONLY VALID FOR 6 MONTHS. EXTENSION MAY BE PURCHASED

Printed Name: _____

Signature: _____

Date: _____

Applications may be submitted in person at the Permit office – 1219 Henry S Thibodaux Street, Thibodaux, LA 70301

OR

Via email to mreulet@ci.thibodaux.la.us or scabrera@ci.thibodaux.la.us

**MOBILE HOME & MODULAR HOME RELOCATION
PERMIT APPLICATION
Thibodaux, Louisiana**

Phone: (985) 446-7208

The undersigned applies for a building permit for the following use, said permit to be issued on the basis of the information contained within this application. The applicant hereby certifies that all information and attachments to this application are true and correct. The applicant is required, in addition to the information requested on this form to submit plans, in duplicate and drawn to scale, showing the actual dimensions and shape of the lot, exact sizes and locations of existing buildings on the lot, and the location and dimensions of the proposed buildings or alterations.

CHECKLIST:

- Permit Fee
- Site Plan
- Completed Application

1. **Building Address:** _____

2. **Name of Owner:** _____

Mailing Address: _____

Phone No.(s): Home: _____ Work: _____ Cell: _____

3. **Name of Contractor:** _____

Mailing Address: _____

Phone No.(s): Office: _____ Cell: _____ Contact: _____

4. **Proposed Use:**

Select One (1):

Residential _____ Commercial _____ Industrial _____

Select Structure Type:

Mobile Home _____ Modular Home _____

5. Structure Dimensions: Width _____ Length _____

6. Lot Area: _____ Percentage of lot to be occupied: _____ %

7. Lot Width: _____ Lot Depth: _____

Page 1 of 2

Applications may be submitted in person at the Permit office – 1219 Henry S Thibodaux Street, Thibodaux, LA 70301
OR

Via email to mreulet@ci.thibodaux.la.us or scabrera@ci.thibodaux.la.us

8. Yard Dimensions: Front: _____ Rear: _____
One Side: _____ Sum of Side Yards: _____

9. **Estimated Project Cost:** _____

NOTE: This permit shall be void if work is not started within six (6) months or completed within 2 years.

Printed Name: _____

Signature: _____

Date:

SHED (PRE-FABRICATED) PERMIT APPLICATION

Thibodaux, Louisiana

Phone: (985) 446-7208

The undersigned applies for a building permit for the following use, said permit to be issued on the basis of the information contained within this application. The applicant hereby certifies that all information and attachments to this application are true and correct. The applicant is required, in addition to the information requested on this form to submit plans, in duplicate and drawn to scale, showing the actual dimensions and shape of the lot, exact sizes and locations of existing buildings on the lot, and the location and dimensions of the proposed buildings or alterations.

CHECKLIST:

- Permit Fee
- Site Plan
- Engineer-Stamped Manufacturing Specs with Wind Speed Rating
- Completed Application
-

1. Building Address: _____

2. Name of Owner: _____

Mailing Address: _____

Phone No.(s): Home: _____ Work: _____ Cell: _____

3. Name of Contractor: _____

Mailing Address: _____

Phone No.(s): Office: _____ Cell: _____ Contact: _____

4. Proposed Use:

Select One (1):

Residential _____ Commercial _____ Industrial _____

5. Lot Area: _____ Percentage of lot to be occupied: _____ %

6. Lot Width: _____ Lot Depth: _____

7. Square Feet of Project Area

Residential (Living): _____ Commercial: _____ Industrial: _____

8. Yard Dimensions: Front: _____ Rear: _____
One Side: _____ Sum of Side Yards: _____

9. Accessory Building Dimensions: Height: _____ Size / Dimensions: _____

10. **Estimated Project Cost:** _____

NOTE: This permit shall be void if work is not started within six (6) months or completed within 2 years.

Printed Name: _____

Signature: _____

Date: _____

RESIDENTIAL POOL PERMIT APPLICATION

Thibodaux, Louisiana

Phone: (985) 446-7208

The undersigned applies for a building permit for the following use, said permit to be issued on the basis of the information contained within this application. The applicant hereby certifies that all information and attachments to this application are true and correct. The applicant is required, in addition to the information requested on this form to submit plans, in duplicate and drawn to scale, showing the actual dimensions and shape of the lot, exact sizes and locations of existing buildings on the lot, and the location and dimensions of the proposed buildings or alterations.

1. **Building Address:** _____

2. **Name of Owner:** _____

Mailing Address: _____

Phone No.(s): Home: _____ Work: _____ Cell: _____

3. **Name of Contractor:** _____

Mailing Address: _____

Phone No.(s): Office: _____ Cell: _____ Contact: _____

4. Lot Area: _____ Percentage of lot to be occupied: _____ %

5. Lot Width: _____ Lot Depth: _____

6. Yard Dimensions: Front: _____ Rear: _____

One Side: _____ Sum of Side Yards: _____

7. **Estimated Project Cost:** _____

NOTE: This permit shall be void if work is not started within six (6) months or completed within 2 years.

Printed Name: _____

Signature: _____

Date: _____

Applications may be submitted in person at the Permit office – 1219 Henry S Thibodaux Street, Thibodaux, LA 70301
OR

Via email to mreulet@ci.thibodaux.la.us or scabrera@ci.thibodaux.la.us

FENCE PERMIT APPLICATION

Thibodaux, Louisiana

Phone: (985) 446-7208

CHECKLIST:

- Permit Fee: \$23.00

- Completed Application

- Site Plan

Property Address: _____

Owner Name: _____

Mailing Address: _____

Phone Number: Home _____ Cell _____ Work _____

Contractor Name: _____

Mailing Address: _____

Phone Number: Home _____ Cell _____ Work _____

Total Length of Fencing: _____

Estimated Cost of Project: _____

Applicant Printed Name

Date

Applications may be submitted in person at the Permit office – 1219 Henry S Thibodaux Street, Thibodaux, LA 70301
OR

Via email to mreulet@ci.thibodaux.la.us or scabrera@ci.thibodaux.la.us



City of Thibodaux

Site Plan

Required Information:

- Lot(s) involved in project
 - Property lines
 - Outline of existing structure(s) on property with dimensions
 - Dimensions and outline of proposed project – new structure, fence, pool, etc
 - Distances between structures and from property lines
 - Driveways
 - Adjacent street(s)
-

Applications may be submitted in person at the Permit office – 1219 Henry S Thibodaux Street, Thibodaux, LA 70301

OR

Via email to mreulet@ci.thibodaux.la.us or scabrera@ci.thibodaux.la.us