



## **ACKNOWLEDGEMENT FORM**

This is to acknowledge that I have received a copy of the City of Thibodaux permit department commercial permit information package for the proposed or planned construction to be performed at the site listed below. I understand that it is my responsibility to provide this information to the individual, owner or contractor that will obtain a permit for the work to be performed at this location. I further understand that the person who obtains the permit shall be responsible to ensure that the construction performed complies with all applicable codes.

Should another copy of the information provided be requested after initial receipt, a duplicate copy fee of \$.50 per sheet shall be payable prior to receipt of this information.

---

Printed Name

---

Signature

---

Permit Address

---

Date

\*\*Please note that this information is also available on the City of Thibodaux's website located at [www.ci.thibodaux.la.us](http://www.ci.thibodaux.la.us). You need to select Public Works Department in white drop down box; then you need to click on Building and Permits section, scroll down until you locate file named Commercial Permit Information Package\*\*

# Commercial Permit Issuance Requirements

Prior to permit issuance the following needs to be submitted for plan review:

- 1) Plan review letter from State Fire Marshal's office
- 2) Two (2) complete sets of plans with State Fire Marshal review stamp consisting of foundation plans, a roof and floor plan including elevation, stairs and landing detail and other details according to plan submittal requirements attached
- 3) Two (2) plot plans showing dimensions and location of structure with all setbacks, servitudes and driveways
- 4) Two (2) plumbing layouts done in red ink to be submitted by licensed plumber separate from complete plans; along with fee calculation sheet (copy attached)
- 5) Two (2) electrical layouts in detail showing fixtures and service to be submitted by licensed electrician separate from complete plans; along with fee calculation sheet (copy attached)
- 6) Two (2) gas layouts (if applicable) done in red ink to be submitted by licensed plumber separate from complete plans; along with fee calculation sheet (copy attached)
- 7) Two (2) landscaping layouts submitted separate from complete plans
- 8) Two (2) mechanical layouts to be submitted separate from complete plans; along with fee calculation sheet (copy attached)

One plan will be kept on file in the Inspector's Office and one plan will be reviewed and returned to the respective contractor and kept on the job at all times for the inspection

## **OTHER REQUIREMENTS:**

- 1) **Permit Application Form must be completed (copy attached)**
- 2) **Proof of bulk disposal container on job site** for disposal of all debris generated by the construction or demolition of a structure. The contractor or owner shall have the option of hauling the debris to a state approved landfill or disposal facility. **The contractor or owner shall provide confirmation of an account or agreement existing with the aforesaid landfill before a permit will be issued.**
- 3) **Proof of toilet facilities for workmen on job site** must be provided before a permit will be issued.
- 4) **ALL BUILDINGS shall floor grade level twelve (12) inches above the nearest downstream manhole cover or the surface of the street.**
- 5) **Compliance with City of Thibodaux sign regulations**
- 6) **Notice to contractors:** Please be advised that according to the City of Thibodaux's Code of Ordinances Section 13-1. "Prohibition against excessive noise and time limitations on certain noise producing activities" there is a time limitation on construction and demolition and **it is unlawful for any person to operate any equipment used in construction work within a residential area between the hours of 9:00 P.M. and 7:00 A.M. the following day.**

## **7) Address Numbers Required**

As per Chapter 6, Section 6-4 of the City of Thibodaux Code of Ordinances, it is the duty and responsibility of every property owner to have residential, commercial or industrial structures numbered as follows:

- a) Numbering **shall be a minimum of four (4) inches, but sizable so as to be seen from the street / roadway, and shall be displayed on the structure on a background of a contrasting color in a prominent place near an outside light.**
- b) If the entrance of a structure is not visible from the road, addressing numbers shall be located on the front of the building.
- c) On a corner lot, the numbers shall face the street named in the address.
- d) Addressing numbers shall be easily visible at night.
- e) Addressing numbers **shall be plain block numerals**, not script or written numbers.

## **8) Stormwater Pollution Prevention Plan (SWPPP)**

Beginning **January 2, 2017** all residential and commercial construction sites will be required to have a Storm Water Pollution Plan (SWPPP) in place prior to the issuance of any construction approvals or building permit(s). A Stormwater Pollution Prevention Plan (SWPPP) is a site-specific document that is required by the Environmental Protection Agency for construction sites that must comply with stormwater discharge requirements. This plan is more than just a sediment and erosion control plan, but it describes all the activities needed to prevent stormwater contamination and comply with the requirements of the Clean Water Act during construction. During the construction phase of a development project, the SWPPP is the means by which the city ensures you do not violate the terms of their LDEQ permit. It is the responsibility of the contractor to prepare the SWPPP, implement it onsite, and inspect and maintain the BMPs during the entire construction period.

During site preparation and clearing, the contractor should plan early. Minimizing the area that is disturbed is crucial to preventing stormwater pollution. There is no need to disturb site areas in which construction will not take place. Soil disturbance and unprotected exposure should be minimized and revegetated and mulched as soon as possible. No construction activities should be allowed outside the construction area limits, including the storage of materials and equipment and the parking of construction and workers vehicles.

Sediment Control BMPs should be put in place as to trap or redirect any sediment leaving the site. Sediment control BMPs include silt fences, check dams, drain inlet protection, and sediment retention basins. Examples of standard silt fences and inlet protection using hay bales are shown below. When using the hay bale method for inlet protection the bales shall remain whole and not be broken apart and laid loose along the top of the disturbed soil.

Periodic inspections will be performed by the city's Certified Stormwater Inspector(s) during the construction phase of the project. Any violations of the policy or the city ordinance can and may result in stop work orders being placed on the project until the violations are corrected and up to fine and penalties for extreme and blatant violations.

Should you have any questions regarding this memo please feel free to contact me at (985) 446-7208 or via email at [mreulet@ci.thibodaux.la.us](mailto:mreulet@ci.thibodaux.la.us).

## Installing a Filter Fabric Silt Fence

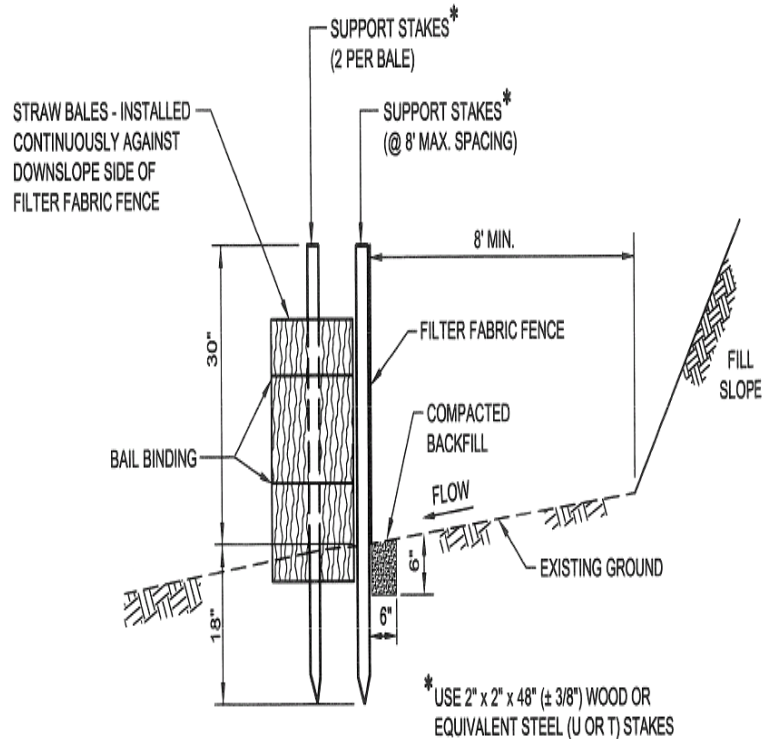
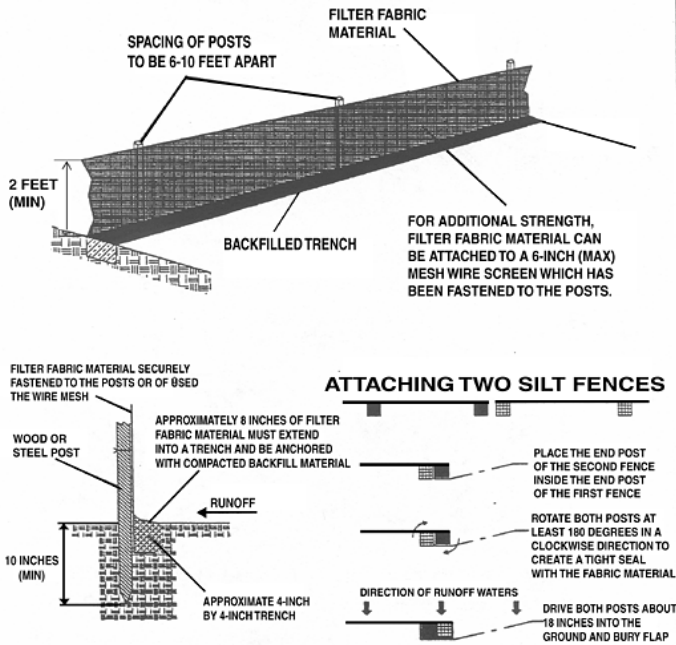

### 9) Storm Water Discharges – Construction Activities

The contractor/owner/operator shall certify all state requirements have been met by signing a certification statement as part of the building permit application.

1. All operators of construction sites shall use best management practices to control and reduce the discharge, to the City of Thibodaux, MS4, and to waters of the United States, of sediment, silt, earth, soil and other material associated with the clearing, grading, excavation, and other construction activities to the maximum extent practicable. Such best management practices may include, but not be limited to, the following measures:

- Ensuring that existing vegetation is preserved where feasible and that disturbed portions of the site are stabilized as soon as practicable in portions of the site where construction activities have temporarily or permanently ceased. Stabilization measures may include: temporary seeding, permanent seeding, mulching, geotextiles, sod stabilization, vegetative buffer strips, protection of trees, preservation of mature vegetation and other appropriate measures;
- Use of structural practices to divert flows from exposed soils, store flows, or otherwise limit runoff and the discharge of pollutants from the site to the extent feasible;
- Minimization of the tracking of sediments off-site by vehicles, the generation of dust, and the escape of other windblown waste from the site;
- Prevention of the discharge of building materials, including cement, lime, concrete and mortar to the City, MS4 or waters of the United States;

- (e) Providing general good housekeeping measures to prevent and contain spills of paints, solvents, fuels, septic waste and other hazardous chemicals and pollutants associated with construction, and to assure proper clean and disposal of any such spills in compliance with state, federal and local requirements;
  - (f) Implementation of proper waste disposal and waste management techniques, including covering waste materials and minimizing ground contact with hazardous chemicals and trash;
  - (g) Timely maintenance of vegetation, erosion and sediment control measures and other best management practices in good and effective operating condition; and
  - (h) Installation of structural measures during the construction process to control pollutants in storm water discharges that will occur after construction operations have been completed. Structural measures should be placed on upland soils to the degree attainable. Such installed structural measures may include, but not be limited to the following: storm water detention structures (including wet ponds); flow attenuation by use of open vegetative swales and natural depressions; other velocity dissipation devices, infiltration of runoff on site; and sequential systems which combine several practices. Operators of construction sites are only responsible for the installation and maintenance of storm water management measures prior to final stabilization of the site and are not responsible for maintenance after storm water discharges associated with construction activity have terminated.
2. Personnel (provided by the operator of the construction site) shall inspect disturbed areas of any construction site (meeting criteria of current NPDES permit) that have not been finally stabilized, areas used for storage of materials that are exposed to precipitation, structural control measures and locations where vehicles enter or exit the site in accordance with the current NPDES permit. All erosion and sediment control measures and other identified best management practices shall be observed in order to ensure that they are operating correctly and are effective in preventing significant impacts to receiving waters, the City and the MS4. Based on the results of the inspections, best management practices shall be revised as appropriate and as soon as is practicable.
  3. The city may require any plans and specifications that are prepared for the construction of site improvement to illustrate and describe the best management practices required by subsection (1) (a) above that will be implemented at the construction site. The city may deny approval of any building permit, site development plan, or any other city approval necessary to commence or continue construction, or to assume occupancy, on the grounds that the management practices described in the plans or observed upon the site inspection by the city are determined not to control and reduce the discharge of sediment, silt, earth, soil and other materials associated with clearing, grading, excavation, and other construction activities to the maximum extent practicable.
  4. Any owner of a site of construction activity, whether or not he/she is an operator, is jointly and severally responsible for compliance with the requirements in this section.
  5. Any contractor or subcontractor on a site of construction activity, who is not an owner or operator, but who is responsible under his/her contract or subcontract for implementing best management practices control measure, is jointly and severally responsible for any willful or negligent failure on his/her part to adequately implement that control measure if such failure causes or contributes to causing the city to violate a water quality standard, the city's NPDES permit, or any state-issued discharge permit for discharges from its MS4.
  6. Based on the results of the inspections required by subsection (2), the site description and/or the pollution prevention measures shall be revised as appropriate, but in no case later than one (1) calendar day following the inspection. Such modifications shall provide for the timely implementation of any changes to the SWPPP within one (1) calendar day following the inspection.
  7. Upon final stabilization of the construction site, the owner of the duly authorized representative thereof shall submit written certification to the city that the site has been finally stabilized. The city may withhold the occupancy or use permit for any premises constructed on the site until certification of final

stabilization has been filed and the city has determined, following any appropriate inspection, that final stabilization has, in fact, occurred and that any required permanent structural controls have been completed.

8. Construction activity, including clearing, grading and excavation activities, that result in the disturbance of one (1) or more acres of total land area shall comply with the requirements of this chapter. This also applies to building construction (including commercial and residential) on lots less than (1) acre. (Ord. 2368, 12-18-07)

## **10) Lock Box System Required**

*The Thibodaux Volunteer Fire Department has determined that the health welfare and safety of the citizens of the City of Thibodaux are promoted by requiring certain structures to have a key lock box installed on the exterior of the structure to aid the Fire Department in gaining access to or within a structure when responding to calls for emergency service, and to aid access into or within a building that is secured or is unduly difficult to gain entry due to being either unoccupied or the occupants are unable to respond.*

1. The following structures that have monitored alarm systems or sprinkler systems shall be equipped with a key lock box at or near the main entrance or such other location as determined by the Fire Chief.

- a) Commercial or Industrial Structures.
- b) Multi-family-residential structures that have restricted access through locked doors but have a common corridor for access to the living units.
- c) Schools, whether public or private.
- d) Government structures and nursing care facilities unless the building is staffed or open 24 hours.

2. All new construction and/or remodeling requiring the issuance of a building permit, that have monitored alarm systems or sprinkler systems, shall have a key lock box installed based on the discretion of the Fire Chief. The key lock box shall be operational prior to the issuance of an occupancy permit. All structures in existence on the effective date of this section, that meet the criteria established in Section 9-59 (1), shall install a key lock box system within six (6) months.

3. The type of key lock boxes to be implemented within the City of Thibodaux shall be a Knox Box brand system.

### **Installation**

1. All Knox Boxes shall be installed to the lock side of the main business door.
2. All Knox Boxes shall be flush or surface mounted approximately five feet from the ground to the center of the entry if possible.
3. In the event that the rapid entry box system cannot be installed at the aforesaid location and/or height the Fire Chief may designate in writing a different location and installation specifications.
4. All realty and/or property with an electronic security gate shall have the Knox Box installed OUTSIDE of the gate.
5. A window decal that is included when the Knox Box is shipped shall be placed on the exterior access door to alert the fire department that a key box is provided.
6. The Fire Chief must approve any changes in the installation.

### **Maintenance**

The operator of the building shall immediately notify the Fire Chief and provide the new keys when a lock is changed or rekeyed. The key to such lock shall be secured in the Knox Box. Operator shall mean the owner of record, tenant, lessee or other person having a possessory or proprietary interest in a commercial building.

### **Exceptions to requirement to install a key lock box**

The following structures are encouraged to, but are exempt from, the mandate to install a key lock box system:

1. Single family structures and multi-family structures that do not meet the definition set forth in Section 9-59 (1) (b).
2. Structures that have 24 hour, 365 day on-site security personnel, or have other personnel on site.
3. Businesses that are open and staffed 24 hours, 365 days per year (which may include but are not limited to, nursing homes, hospitals, police stations, etc.).
4. Rental storage facilities where there is a single lock on the separate storage pods that are renter supplied; provided, however, the entry security gates(s) will require a Knox Box if electronically controlled, or locked with a master key issued by the landlord to all tenants.

### **Contents of lock box**

Each lock box on each commercial building shall contain a properly labelled key or keys which will allow access by the fire department to the building, and all rooms or corridors within the building, in the event of an emergency call to that building.

**Penalties**

Any business or person who violates, neglects, or refuses to comply with any provision of this chapter shall be issued a misdemeanor summons, and upon conviction thereof, be fined not less than \$100 or more than \$750 for each offense, and such person shall be deemed guilty of a separate offense if the key lock box system is not installed within sixty (60) days of conviction.

# CITY OF THIBODAUX

## Building Code Requirements

### **Building codes:**

Residential construction — 2021 International Residential Code

Commercial construction— 2021 International Building Code

2021 International Existing Building Code

\*Option of           \*  
Choosing one       \*  
or more            ICC 600-2014 Standard for Residential Construction in High Wind Regions  
                          2015 Wood Frame Construction Manual for 1 & 2 Family Dwellings

### **Electrical codes:**

2020 National Electrical Code

2018 Entergy Customer Installation Standards

### **Plumbing codes:**

2021 International Plumbing Code

### **Gas code:**

2021 International Fuel Gas Code

### **Mechanical code:**

2021 International Mechanical Code

### **ADA:**

American National Standard – Accessible & Usable Buildings & Facilities



# **PLAN SUBMITTAL REQUIREMENTS**

## **Governing Codes**

Building  
Electrical  
Mechanical  
Plumbing  
Gas  
Basic wind speed  
Occupancy Classification  
Construction Type

## **Site Plan**

Owner or Contractor Name  
Lot and block number  
Street address  
Lot description  
Setbacks  
Width and length of Parking Spaces & Aisles

## **Floor Plan**

Square footage of living  
Square footage of non-living  
Door and window schedule  
Ceiling height  
Location of smoke alarms

## **Roof Plan**

Roof layout  
Roof pitch  
Ridge cap detail

## **Elevations**

Front  
Right side  
Left side  
Rear

## **Foundation Plan**

Exterior grade beams  
Interior grade beams  
Anchor bolts for bottom plate  
Shear wall hold downs

## **Framing Plan**

Exterior wall sections  
Cross sections of building  
Bracing of attic  
Gable end wall  
Ceiling joist framing  
Shear wall sheathing panel bracing  
Location of shear walls  
Profile of columns/post anchoring  
Type & location of hurricane straps  
Note on how glazing will be protected  
DP rating for windows

## **Plumbing Plan**

Plumbing site  
Plumbing below slab  
Plumbing isometrics  
Plumbing above slab

## **Electrical Plan**

Electrical site plan  
Power floor plan  
Lighting floor plan  
Electrical riser diagram  
Panel board schedule  
Panel location and size  
Label circuits

## **Mechanical Plan**

Mechanical floor plan  
Equipment layout (sizes)  
Duct work layout (sizes)

# CITY OF THIBODAUX

## Permit Fee Rates

### **COMMERCIAL CONSTRUCTION PERMIT FEES**

\$100,000.00 and less.....Fee = \$ 3.00 / thousand  
\$101,000.00 to \$500,000.00 .....Fee = \$ 300.00 + \$2.00 / \$1,000 above \$100,000.00  
\$501,000.00 and over .....Fee = \$1,100.00 + \$1.50 / \$1,000 above \$500,000.00

### **RESIDENTIAL CONSTRUCTION PERMIT FEES**

\$100,000.00 and less.....Fee = \$ 2.50 / thousand  
\$101,000.00 to \$500,000.00 .....Fee = \$ 250.00 + \$2.00 / \$1,000 above \$100,000.00  
\$501,000.00 and over .....Fee = \$1,050.00 + \$1.50 / \$1,000 above \$500,000.00

**OTHER STRUCTURES** (Including but not limited to): Swimming pools, renovations, open porches and canopies, fire damage, shell buildings, etc.  
Fee = \$3.00 / thousand

**Minimum Permit Fee** .....Fee = \$40.00 (applies to commercial & residential)

### **OTHER PERMIT FEES / AMOUNTS**

Demolition .....Fee = \$50.00  
Driveway Curb-Cut .....Fee = \$10.00  
90 Day Extension .....Fee = \$20.00  
Re-inspection.....Fee = \$50.00

### **SIGN PERMIT FEES**

1 to 25 sq. feet .....Fee = \$ 25.00  
26 to 99 sq. feet .....Fee = \$ 50.00  
100 + sq. feet.....Fee = \$100.00+\$1.50 / sq.ft. over

### **ZONING PERMIT FEES**

Fence ..... Fee = \$23.00  
Manufactured Home Relocation ..... Fee = \$40.00  
Home Relocation (owner) ..... Fee = \$40.00  
Home Relocation (mover)..... Fee = \$100.00  
Occupancy / Building ..... Fee = \$40.00  
Occupancy / Zoning..... Fee = \$23.00  
Telephone/Mail Use ..... Fee = \$23.00  
Variance Application ..... Fee = \$30.00

**All fees must be paid by check, money order or Visa/Mastercard prior to permit issuance.**

**Any work performed without permit issuance is subject to double fees.**

# CITY OF THIBODAUX

## Inspection Requirements

**Building inspection** shall be performed in the foundation, framing and completion stages

**Electrical inspection** shall be performed in the foundation, rough-in and completion stages

**Plumbing inspection** shall be performed in the foundation, rough-in and completion stages

**Gas inspection** shall be performed in the rough-in and completion stages

**Mechanical inspection** shall be performed in the rough-in and completion stages

**Any additional inspections that may be required**

**Phone number to call for Building, Electrical, Plumbing, Gas & Mechanical Inspections: 985-446-7208 or 985-446-7205**

Request(s) for inspection must be made by the respective building contractor, electrician and plumber performing the work at the job site. **Contractors have to allow the inspection department up to forty-eight (48) hours to perform inspections from the time the inspection request is received.**

## Permit Cards

No inspections shall be performed without the permit being displayed on the job site.

The permit holder shall post the permit on the job site where they are visible from the road. The permit shall be maintained by the permit holder until the final inspection has been made and approved.

**Re-inspection fee of fifty dollars (\$50.00) may be charged for any additional inspections required after any of the initial free inspections referenced above.**

## Certificate of Occupancy

A certificate of occupancy will be issued upon completion of all inspections and the payment of all cost associated with the inspections have been paid in full. **No one shall be allowed to furnish or move in until certificate of occupancy has been issued.**

## Zoning Compliance Certificate

A certificate of zoning compliance will be issued upon completion of all inspections and the payment of all cost associated with the inspections have been paid in full. **No one shall be allowed to furnish or move in until certificate of zoning compliance has been issued.**

**CITY OF THIBODAUX**  
**REGISTRATION REQUIREMENTS - Electricians**

Electrical Registration Requirements

All electrical work to be performed within the City limits shall be performed by a City registered electrician. In order to obtain a City electrical registration, contractor shall be required to furnish the Inspection Department with a copy of their State electrical license. If contractor is not licensed state-wide, they have the option to take an electrical examination administered quarterly by the Inspection Department. Electrical examinations are typically scheduled in the months of January, April, July and October on the 1<sup>ST</sup> Wednesday of the month.

In addition, electrical contractor shall be required to furnish the Inspection Department with a \$2,000.00 contractor's or performance bond and liability insurance in the amount of \$20,000 as required by City ordinance.

**These items may be furnished to the Inspection Department by either fax, email, mail or at office.**

Email Addresses: [mreulet@ci.thibodaux.la.us](mailto:mreulet@ci.thibodaux.la.us) or [scabrera@ci.thibodaux.la.us](mailto:scabrera@ci.thibodaux.la.us)

Physical Address: **1219 Henry S. Thibodaux Street, Thibodaux, LA**

Mailing Address: **City of Thibodaux, Inspection Dept., P. O. Box 5418, Thibodaux, LA 70302**

**Once the Inspection Department is in receipt of these items, a release form shall be forwarded to the "Tax and License Department."** Contractor should contact Tax & License Department at (985) 446-7221 for further information regarding obtaining a City electrical registration.

**NOTE: Homeowners do have the right to perform their own electrical work provided they are knowledgeable of the electrical code requirements. However, should the electrical work that is performed by the homeowner demonstrate that they do not know the applicable code requirements, they shall be required to obtain a City registered electrician. All work performed is subject to and shall be inspected.**

**ELECTRICAL PERMIT FEE CALCULATION SHEET**

**Thibodaux, Louisiana**

Phone: (985) 446-7208

**Electrician's Name & Mailing Address:**

┌ \_\_\_\_\_ ┐  
\_\_\_\_\_  
\_\_\_\_\_  
\_\_\_\_\_  
└ \_\_\_\_\_ ┘

**Date:** \_\_\_\_\_

**Property Owner:** \_\_\_\_\_

**Project Address:** \_\_\_\_\_

**Entergy Acct #:** \_\_\_\_\_

**Name on Acct:** \_\_\_\_\_

**Description**

**FEEES ASSOCIATED WITH ABOVE ELECTRICAL INSTALLATION**

- Entergy Service Inspection ..... \_\_\_\_\_
- Main electrical service      Amperage of Service ..... \_\_\_\_\_
- Main panels                      Amperage of Panels ..... \_\_\_\_\_
- Automatic Transfer Switch      Amperage of ATS..... \_\_\_\_\_
- Square ft. living (inspection) ..... \_\_\_\_\_
- Square ft. other (inspection) ..... \_\_\_\_\_
- Temporary electrical service .....Number of Services..... \_\_\_\_\_
- Air Conditioner Systems .....Amperage of units..... \_\_\_\_\_
- .....
- Square ft. living (plan review) ..... \_\_\_\_\_
- Square ft. other (plan review) ..... \_\_\_\_\_
- Parking lot lighting .....Number of Lights..... \_\_\_\_\_
- Other: \_\_\_\_\_
- \_\_\_\_\_
- \_\_\_\_\_

**TOTAL ELECTRICAL VALUE: \$** \_\_\_\_\_

**SIGNATURE VERIFICATION:** \_\_\_\_\_

**All fees must be paid by check, money order or Visa/Mastercard/Discover prior to permit issuance.  
\*\*\*Any work performed without permit issuance is subject to double fees.\*\*\***

**CITY OF THIBODAUX**  
**REGISTRATION REQUIREMENTS - Plumbers**

Plumbing Registration Requirements

All plumbing work to be performed within the City limits shall be performed by a City registered plumber. In order to obtain a City plumbing registration, contractor shall be required to furnish the Inspection Department with a copy of their State plumbing license.

In addition, plumbing contractor shall be required to furnish the Inspection Department with a \$5,000.00 contractor's or performance bond as required by City ordinance.

These items may be furnished to the Inspection Department by either fax, email, mail or at office.

Email address: [mreulet@ci.thibodaux.la.us](mailto:mreulet@ci.thibodaux.la.us) or [scabrera@ci.thibodaux.la.us](mailto:scabrera@ci.thibodaux.la.us)

Physical Address: 1219 Henry S. Thibodaux Street, Thibodaux, LA

Mailing Address: City of Thibodaux, Inspection Dept., P.O. Box 5418, Thibodaux, LA 70302

Once the Inspection Department is in receipt of these items, a release form shall be forwarded to the "Tax and License Department." Contractor should contact Tax & License Department at (985) 446-7221 for further information regarding obtaining a City plumbing registration.



City of Thibodaux  
City Inspector's Office  
P.O. Box 5418  
Thibodaux, Louisiana 70302

Phone: 985-446-7208

**PLUMBING FEE CALCULATION SHEET**

Plumber's Name & Mailing Address:

\_\_\_\_\_  
\_\_\_\_\_  
\_\_\_\_\_

Property Owner: \_\_\_\_\_

Address: \_\_\_\_\_

Date: \_\_\_\_\_

*Description*

**FIXTURES ASSOCIATED WITH ABOVE PLUMBING INSTALLATION**

Water Closets .....	(6.00)	_____
Tubs .....	(6.00)	_____
Shower .....	(6.00)	_____
Lavatories .....	(6.00)	_____
Sinks .....	(6.00)	_____
Clothes Washer .....	(6.00)	_____
Dish Washer .....	(6.00)	_____
Floor Drains .....	(6.00)	_____
A/C Drains.....	(6.00)	_____
Water Heater.....	(6.00)	_____
Water Service .....	(8.00)	_____
Lawn & Roof Sprinklers .....	(8.00)	_____
Vaccuum Breaker .....	(8.00)	_____
Drinking Fountains.....	(6.00)	_____
Urinals.....	(6.00)	_____
Rough In.....	(32.00)	_____
Sewer Tie In.....	(32.00)	_____
Sewer Service.....	(48.00)	_____
Sewer Extension .....	(32.00)	_____
Re-inspection Fee.....	(50.00)	_____
Other .....		_____

**All fees must be paid by check, money order or Visa/Mastercard prior to permit issuance.  
Any work performed without permit issuance is subject to double fees.**

**SIGNATURE VERIFICATION:** \_\_\_\_\_

**CITY OF THIBODAUX**  
**REGISTRATION REQUIREMENTS**  
Mechanical Contractors

Mechanical Registration Requirements

All mechanical work to be performed within the City limits shall be performed by a City registered mechanical contractor. In order to obtain a City mechanical registration, contractor shall be required to furnish the Inspection Department with a copy of their State mechanical or State plumbing license.

In addition, mechanical contractor shall be required to furnish the Inspection Department with a \$5,000.00 contractor's surety or performance bond and liability insurance in the amount of \$100,000 as required by City ordinance.

These items may be furnished to the Inspection Department by either fax, email, mail or at our office.

Email Address: [mreulet@ci.thibodaux.la.us](mailto:mreulet@ci.thibodaux.la.us) or [scabrera@ci.thibodaux.la.us](mailto:scabrera@ci.thibodaux.la.us)

Physical Address: 1219 Henry S. Thibodaux Street, Thibodaux, LA

Mailing Address: City of Thibodaux, Inspection Dept., P.O. Box 5418, Thibodaux, LA 70302

Once the Inspection Department is in receipt of these items, a release form shall be forwarded to the "Tax and License Department." Contractor should contact Tax & License Department at (985) 446-7221 for further information regarding obtaining a City plumbing registration.

**NOTE: Homeowners do have the right to perform their own mechanical work** provided they are knowledgeable of the mechanical code requirements. **However, should the mechanical work that is performed by the homeowner demonstrate that they do not know the applicable code requirements, they shall be required to obtain a City registered mechanical contractor. All work performed is subject to and shall be inspected.**





**PERMIT APPLICATION FORM**  
**Commercial Mechanical**  
**CITY OF THIBODAUX**  
**P. O. Box 5418**  
**Thibodaux, LA 70302**

**PH: 985-446-7208**

Contractor's Name & Mailing Address:

DATE: \_\_\_\_\_

┌ \_\_\_\_\_ ┐  
 \_\_\_\_\_  
 \_\_\_\_\_  
 \_\_\_\_\_  
 └ \_\_\_\_\_ ┘

**Property Owner:** \_\_\_\_\_  
**Address:** \_\_\_\_\_

These fees will have application to all types of mechanical installations, inside and outside the main structure on the same parcel of property. These fees apply to structures not to be used as a dwelling unit.

<b>CODE</b>	<b>ITEM</b>	<b>QUANTITY</b>	<b>PRICE</b>
M09	AC Unit 0-4+ Tons		45.00
M10	AC Unit 5-9+ Tons		65.00
M11	AC Unit >10 Tons (each ton)		8.00
M12	Refrig. 0-4+ HP		45.00
M13	Refrig. 5-9+ HP		60.00
M14	Refrig. >10 HP (each HP)		7.00
M15	Refrig. Cooler/ Freezer		45.00
M16	Cooling/Heating Coil		14.00
M17	Hoods		45.00
M18	Commercial Clothes Dryer		31.00
M19	Incinerator		40.00
M20	Boiler		65.00
M21	Heater unit		27.00
M22	Heater Duct <=25 Tons		27.00
M23	Heater Duct > 25 Tons (ea)		8.00
M24	Duct Alteration		31.00
M25	Cooling Tower		85.00
M26	Mobile Home, CMRCL		22.00
M27	Mobile Home, SFR		12.00
M28	Fire Extinguishing System		45.00
M29	Change out 0-4+ Tons		45.00
M30	Change Out 5-9+ Tons		65.00
M31	Change Out>10 Tons (ea.)		2.00
M32	Change Out Heater Only		31.00
M33	Change Out Condenser Only		31.00
M34	Permit Reinstatement		40.00
M35	Minimum Fee		25.00
M36	Plan Review .02 x sq.ft.	.02 x _____	_____

**TOTAL MECHANICAL VALUE: \$** \_\_\_\_\_

**SIGNATURE VERIFICATION:** \_\_\_\_\_

**All fees must be paid by check, money order or Visa/Mastercard prior to permit issuance.**  
**\*\*\*Any work performed without permit issuance is subject to double fees.\*\*\***

# **CITY OF THIBODAUX**

## **GAS INSPECTION INFORMATION**

### **Plan Review**

The customer or plumber is required to submit two sets of plans showing the proposed location of new gas piping drawn in red. The size of the pipe, location of isolation valves and the number of fixtures to be served with gas must also be marked on the plans. These plans must be accompanied with a Fixtures Sheet which includes the plumbers name, mailing address, license number, owner's name, address and date of submittal. A list of fixtures associated with natural gas and BTU demand must also be provided at the same time. Both sets are reviewed for compliance with all codes and City ordinances, changes are noted on the plans, stamped, signed and dated. One set remains in the office of the Gas Superintendent and the other returned to the customer or plumber who submitted the plans to follow during pipe installation.

## **INSPECTIONS REQUIRED**

### **Gas Open Wall Inspection**

After the gas piping is installed according to the plans approved and piping ready for inspection, the plumber must contact the Permits Division of Public Works at 446-7208 to request a gas open wall inspection. The inspection will be conducted within two working days of the request. The plumber will be contacted to inform them of the results of the inspection as well as to inform them of any violations discovered.

### **Gas Pipe Pressure Test**

After passing the gas open wall inspection, the gas piping must be tested to assure that there are no leaks. The test will be a minimum of 16 oz. and hold for 15 minutes with no loss of pressure. Test pressure shall be measured with a manometer or with a pressure-measuring device designed and calibrated to read, record or indicate a pressure loss caused by leakage during the pressure test period. The source of pressure shall be isolated before the pressure tests are made. Mechanical gauges used to measure test pressures shall have a range such that the highest end of the scale is not greater than five times the test pressure. The plumber must contact the Permits Division of Public Works at 446-7208 to request a gas pressure test for customer piping. The inspection will be conducted within two working days of the request. The plumber will be contacted to inform them of the results of the test.

### **Gas Final Inspection**

After passing inspections for both the gas open wall and gas pipe pressure test and all related costs have been paid, the Gas and Water Division of Public Works will install the gas meter and gas regulator to serve the structure. The customer's plumber must then connect the customer's pipe to the outlet side of the gas meter and install a test tee with 1/4" outlet and plug on the downstream side of the gas meter. The customer's plumber must then connect and test all gas fixtures for leaks and repair before calling the Permits Division to request a gas final inspection. The inspection will be conducted within two working days of the request if entry is possible.

**NOTE: All work done on gas piping in the City of Thibodaux must be done by a registered plumber or mechanical contractor, inspected and documented before gas service will be activated.**

# GENERATOR INSTALL PERMIT INFORMATION SHEET

## Thibodaux, Louisiana

Phone: (985) 446-7208

1. City - Registered Electrician must pull permit for Electrical portion of project. They must provide:

-Amperage of Service (If Replacing or Upgrading)

-Amperage of Transfer Switch (Under "Panels")

\* The panel/service must pass inspection prior to the reconnect order being issued to Entergy.

2. City - Registered Plumber OR Mechanical Contractor must pull permit for Gas portion of project. They must provide:

-List of all existing gas fixtures, and the BTU's for each.

-The BTU's of the new fixture (Generator)

\* A pressure test must be completed and passed prior to a gas meter being installed and project being completed.



City of Thibodaux
P.O. Box 5418
Thibodaux, Louisiana 70302

Gas & Water- 985-446-7216
Permits- 985-446-7208

GAS PERMIT FEE CALCULATION SHEET

Plumber's Name & Mailing Address:

Form with three horizontal lines for name and address, flanked by corner brackets.

Property Owner: \_\_\_\_\_

Address: \_\_\_\_\_

Date: \_\_\_\_\_

Description

Please provide fixtures associated with above natural gas installation and/or existing fixtures.

\*\*Label each fixture as Existing (E) or New (N)\*\*

EQUIPMENT DESCRIPTION

Table with columns: EQUIPMENT DESCRIPTION, QUANTITY, BTU's. Includes rows for Gas Meter Loop & Gas Piping System Test, Central Heat, Water Heater, Clothes Dryer, Kitchen Stove, Fireplace, Gas Lights, Generator, Other, and a TOTAL BTU DEMAND row.

All fees must be paid by check, money order or Visa/Mastercard prior to permit issuance.
Any work performed without permit issuance is subject to double fees.

SIGNATURE VERIFICATION: \_\_\_\_\_

# NEW CONSTRUCTION BUILDING PERMIT APPLICATION

## Thibodaux, Louisiana

Phone: (985) 446-7208

The undersigned applies for a building permit for the following use, said permit to be issued on the basis of the information contained within this application. The applicant hereby certifies that all information and attachments to this application are true and correct. The applicant is required, in addition to the information requested on this form to submit plans, in duplicate and drawn to scale, showing the actual dimensions and shape of the lot, exact sizes and locations of existing buildings on the lot, and the location and dimensions of the proposed buildings or alterations.

1. **Locational Description:** Subdivision Name \_\_\_\_\_  
Block: \_\_\_\_\_ Lot: \_\_\_\_\_

**Building Address:** \_\_\_\_\_

2. **Name of Owner:** \_\_\_\_\_

Mailing Address: \_\_\_\_\_

**Phone No.(s):** Home: \_\_\_\_\_ Work: \_\_\_\_\_ Cell: \_\_\_\_\_

3. **Name of Contractor:** \_\_\_\_\_

**Mailing Address:** \_\_\_\_\_

**Phone No.(s):** Office: \_\_\_\_\_ Cell: \_\_\_\_\_ Contact: \_\_\_\_\_

4. **Proposed Use:**

Select One (1): Residential \_\_\_\_\_ Commercial \_\_\_\_\_ Industrial \_\_\_\_\_

Select Type of New Construction: Principal Building: \_\_\_\_\_ Accessory Building \_\_\_\_\_

Residence \_\_\_\_\_ # of Units \_\_\_\_\_ Other (Explain) \_\_\_\_\_

\_\_\_\_\_  
(If proposed site is commercial or industrial furnish description of the nature of the business or industry.)

6. Lot Area: \_\_\_\_\_ Percentage of lot to be occupied: \_\_\_\_\_ %

7. Lot Width: \_\_\_\_\_ Lot Depth: \_\_\_\_\_

8. Square Feet of Project – Area Residential (Living): \_\_\_\_\_

Commercial: \_\_\_\_\_ Industrial: \_\_\_\_\_

9. Building Height: Stories: \_\_\_\_\_ Feet: \_\_\_\_\_

10. Yard Dimensions: Front: \_\_\_\_\_ Rear: \_\_\_\_\_

One Side: \_\_\_\_\_ Sum of Side Yards: \_\_\_\_\_

11. Accessory Building Dimensions: Height: \_\_\_\_\_ Size / Dimensions: \_\_\_\_\_

12. Number of off-street parking spaces to be provided: \_\_\_\_\_

Applications may be submitted in person at the Permit office – 1219 Henry S Thibodaux Street, Thibodaux, LA 70301

OR

Via email to [mreulet@ci.thibodaux.la.us](mailto:mreulet@ci.thibodaux.la.us) or [scabrera@ci.thibodaux.la.us](mailto:scabrera@ci.thibodaux.la.us)

- 13. Number of off-street loading berths to be provided: \_\_\_\_\_
- 14. On a separate sheet attach a list of other supplemental requirements or conditions that will be met, or explain any points you feel need clarification.
- 15. **Estimated Project Cost:** \_\_\_\_\_

**NOTE: This permit shall be void if work is not started within six (6) months or completed within 2 years.**

**Printed Name:** \_\_\_\_\_

**Signature:** \_\_\_\_\_

**Date:** \_\_\_\_\_

-----  
**(For Official Use Only)**

Date Application Received: \_\_\_\_\_

Fee Paid: \_\_\_\_\_

Date of Action on Application: \_\_\_\_\_

Approved \_\_\_\_\_ Denied \_\_\_\_\_

If application denied, reason(s) for denial:

\_\_\_\_\_

\_\_\_\_\_

\_\_\_\_\_

\_\_\_\_\_

\_\_\_\_\_

\_\_\_\_\_

\_\_\_\_\_  
 Zoning Administrator

# COMMERCIAL BUILD-OUT PERMIT APPLICATION

Thibodaux, Louisiana

Phone: (985) 446-7208

The undersigned applies for a building permit for the following use, said permit to be issued on the basis of the information contained within this application. The applicant hereby certifies that all information and attachments to this application are true and correct. The applicant is required, in addition to the information requested on this form to submit plans, in duplicate and drawn to scale, showing the actual dimensions and shape of the lot, exact sizes and locations of existing buildings on the lot, and the location and dimensions of the proposed buildings or alterations.

## CHECKLIST:

- Permit Fee
- Site Plan - to include drawing of Shopping Center/Strip Mall with your spaces indicated.
- State Fire Marshall - stamped Construction Plans
- State Fire Marshall Plan Review Report
- Completed Application

1. **Building Address:** \_\_\_\_\_

2. **Name of Business Owner/Operator:** \_\_\_\_\_

Mailing Address: \_\_\_\_\_

**Phone No.(s):** Home: \_\_\_\_\_ Work: \_\_\_\_\_ Cell: \_\_\_\_\_

3. **Name of Contractor:** \_\_\_\_\_

**Mailing Address:** \_\_\_\_\_

**Phone No.(s):** Office: \_\_\_\_\_ Cell: \_\_\_\_\_ Contact: \_\_\_\_\_

4. **Square Feet of Project Area:** \_\_\_\_\_

5. **Estimated Project Cost:** \_\_\_\_\_

**NOTE:** This permit shall be void if work is not started within six (6) months or completed within 2 years.

**Printed Name:** \_\_\_\_\_

**Signature:** \_\_\_\_\_

**Date:** \_\_\_\_\_

Applications may be submitted in person at the Permit office – 1219 Henry S Thibodaux Street, Thibodaux, LA 70301  
OR

Via email to [mreulet@ci.thibodaux.la.us](mailto:mreulet@ci.thibodaux.la.us) or [scabrera@ci.thibodaux.la.us](mailto:scabrera@ci.thibodaux.la.us)

# RENOVATION/ADDITION BUILDING PERMIT APPLICATION

Thibodaux, Louisiana

Phone: (985) 446-7208

The undersigned applies for a building permit for the following use, said permit to be issued on the basis of the information contained within this application. The applicant hereby certifies that all information and attachments to this application are true and correct. The applicant is required, in addition to the information requested on this form to submit plans, in duplicate and drawn to scale, showing the actual dimensions and shape of the lot, exact sizes and locations of existing buildings on the lot, and the location and dimensions of the proposed buildings or alterations.

## CHECKLIST:

- Permit Fee
- Site Plan
- Completed Application

1. **Building Address:** \_\_\_\_\_

2. **Name of Owner:** \_\_\_\_\_

Mailing Address: \_\_\_\_\_

**Phone No.(s):** Home: \_\_\_\_\_ Work: \_\_\_\_\_ Cell: \_\_\_\_\_

3. **Name of Contractor:** \_\_\_\_\_

**Mailing Address:** \_\_\_\_\_

**Phone No.(s):** Office: \_\_\_\_\_ Cell: \_\_\_\_\_ Contact: \_\_\_\_\_

## 4. **Proposed Use:**

Select One (1):

Residential \_\_\_\_\_ Commercial \_\_\_\_\_ Industrial \_\_\_\_\_

Select Project Type:

Alteration/Addition \_\_\_\_\_ Accessory Building \_\_\_\_\_

Re-roofing \_\_\_\_\_ Other (Explain) \_\_\_\_\_

**Page 1 of 2**

6. Lot Area: \_\_\_\_\_ Percentage of lot to be occupied: \_\_\_\_\_ %

Applications may be submitted in person at the Permit office – 1219 Henry S Thibodaux Street, Thibodaux, LA 70301  
OR

Via email to [mreulet@ci.thibodaux.la.us](mailto:mreulet@ci.thibodaux.la.us) or [scabrera@ci.thibodaux.la.us](mailto:scabrera@ci.thibodaux.la.us)



7. Lot Width: \_\_\_\_\_ Lot Depth: \_\_\_\_\_

8. **Square Feet of Project Area**

Residential (Living): \_\_\_\_\_ Commercial: \_\_\_\_\_ Industrial: \_\_\_\_\_

9. Yard Dimensions: Front: \_\_\_\_\_ Rear: \_\_\_\_\_

One Side: \_\_\_\_\_ Sum of Side Yards: \_\_\_\_\_

10. Dimensions of Addition: Height: \_\_\_\_\_ Size/Dimensions: \_\_\_\_\_

11. **Estimated Project Cost:** \_\_\_\_\_

**NOTE: This permit shall be void if work is not started within six (6) months or completed within 2 years.**

**Printed Name:** \_\_\_\_\_

**Signature:** \_\_\_\_\_

**Date:** \_\_\_\_\_

# DEMOLITION PERMIT APPLICATION

Thibodaux, Louisiana

Phone: (985) 446-7208

The undersigned applies for a building permit for the following use, said permit to be issued on the basis of the information contained within this application. The applicant hereby certifies that all information and attachments to this application are true and correct. The applicant is required, in addition to the information requested on this form to submit plans, in duplicate and drawn to scale, showing the actual dimensions and shape of the lot, exact sizes and locations of existing buildings on the lot, and the location and dimensions of the proposed buildings or alterations.

## CHECKLIST:

- Permit Fee
- Completed Application

1. **Building Address:** \_\_\_\_\_

2. **Name of Owner:** \_\_\_\_\_

Mailing Address: \_\_\_\_\_

Phone No.(s): Home: \_\_\_\_\_ Work: \_\_\_\_\_ Cell: \_\_\_\_\_

3. **Name of Contractor:** \_\_\_\_\_

Mailing Address: \_\_\_\_\_

Phone No.(s): Office: \_\_\_\_\_ Cell: \_\_\_\_\_ Contact: \_\_\_\_\_

4. **Property Type:**

Select One (1):

Residential \_\_\_\_\_ Commercial \_\_\_\_\_ Industrial \_\_\_\_\_

5. **Select Demolition Type:**

Partial Demolition \_\_\_\_\_ Complete Demolition \_\_\_\_\_

\*\*If partial demolition, please provide plans indicating scope of work/work area. \*\*

6. **Estimated Project Cost:** \_\_\_\_\_

**NOTE: This permit shall be void if work is not started within six (6) months or completed within 2 years.**

**PERMIT IS ONLY VALID FOR 6 MONTHS. EXTENSION MAY BE PURCHASED**

**Printed Name:** \_\_\_\_\_

**Signature:** \_\_\_\_\_

**Date:** \_\_\_\_\_

Applications may be submitted in person at the Permit office – 1219 Henry S Thibodaux Street, Thibodaux, LA 70301  
OR

Via email to [mreulet@ci.thibodaux.la.us](mailto:mreulet@ci.thibodaux.la.us) or [scabrera@ci.thibodaux.la.us](mailto:scabrera@ci.thibodaux.la.us)

# SHED (PRE-FABRICATED) PERMIT APPLICATION

## Thibodaux, Louisiana

Phone: (985) 446-7208

The undersigned applies for a building permit for the following use, said permit to be issued on the basis of the information contained within this application. The applicant hereby certifies that all information and attachments to this application are true and correct. The applicant is required, in addition to the information requested on this form to submit plans, in duplicate and drawn to scale, showing the actual dimensions and shape of the lot, exact sizes and locations of existing buildings on the lot, and the location and dimensions of the proposed buildings or alterations.

### CHECKLIST:

- Permit Fee
- Site Plan
- Engineer-Stamped Manufacturing Specs with Wind Speed Rating
- Completed Application
- 

1. **Building Address:** \_\_\_\_\_

2. **Name of Owner:** \_\_\_\_\_

Mailing Address: \_\_\_\_\_

**Phone No.(s):** Home: \_\_\_\_\_ Work: \_\_\_\_\_ Cell: \_\_\_\_\_

3. **Name of Contractor:** \_\_\_\_\_

Mailing Address: \_\_\_\_\_

**Phone No.(s):** Office: \_\_\_\_\_ Cell: \_\_\_\_\_ Contact: \_\_\_\_\_

### 4. **Proposed Use:**

Select One (1):

Residential \_\_\_\_\_ Commercial \_\_\_\_\_ Industrial \_\_\_\_\_

6. Lot Area: \_\_\_\_\_ Percentage of lot to be occupied: \_\_\_\_\_ %

7. Lot Width: \_\_\_\_\_ Lot Depth: \_\_\_\_\_

### 8. **Square Feet of Project Area**

Residential (Living): \_\_\_\_\_ Commercial: \_\_\_\_\_ Industrial: \_\_\_\_\_

9. Yard Dimensions: Front: \_\_\_\_\_ Rear: \_\_\_\_\_  
One Side: \_\_\_\_\_ Sum of Side Yards: \_\_\_\_\_

10. Accessory Building Dimensions: Height: \_\_\_\_\_ Size / Dimensions: \_\_\_\_\_

11. **Estimated Project Cost:** \_\_\_\_\_

**NOTE: This permit shall be void if work is not started within six (6) months or completed within 2 years.**

**Printed Name:** \_\_\_\_\_

**Signature:** \_\_\_\_\_

**Date:** \_\_\_\_\_

**BILLBOARD/SIGNAGE PERMIT APPLICATION**  
Thibodaux, Louisiana

Phone: (985) 446-7208

P.O. Box 5418, Thibodaux, LA 70302

CHECKLIST:

- Permit Fee:
- Completed Application
- Plans/Drawings

**Property Address:** \_\_\_\_\_

**Zoning District:** \_\_\_\_\_

**Business Name:** \_\_\_\_\_

**Owner/Operator Name:** \_\_\_\_\_

Mailing Address: \_\_\_\_\_

Phone Number: Home \_\_\_\_\_ Cell \_\_\_\_\_ Work \_\_\_\_\_

**Contractor Name:** \_\_\_\_\_

Mailing Address: \_\_\_\_\_

Phone Number: Home \_\_\_\_\_ Cell \_\_\_\_\_ Work \_\_\_\_\_

**Distance of Building Front from Road:** \_\_\_\_\_

**Sign Size** (in square feet): \_\_\_\_\_

**Sign Dimensions:** \_\_\_\_\_

**Select Sign Type** (Circle all that apply):

Mansard      Monument      Pylon      Billboard      Digital Sign/EMC      Wall Sign      Channel Lettering

Illuminated Box      Non-Illuminated Box      Other: \_\_\_\_\_

\_\_\_\_\_  
**Applicant Printed Name**

\_\_\_\_\_  
**Date**

\_\_\_\_\_  
**Applicant Signature**

# RESIDENTIAL/COMMERCIAL POOL PERMIT APPLICATION

Thibodaux, Louisiana

Phone: (985) 446-7208

The undersigned applies for a building permit for the following use, said permit to be issued on the basis of the information contained within this application. The applicant hereby certifies that all information and attachments to this application are true and correct. The applicant is required, in addition to the information requested on this form to submit plans, in duplicate and drawn to scale, showing the actual dimensions and shape of the lot, exact sizes and locations of existing buildings on the lot, and the location and dimensions of the proposed buildings or alterations.

1. **Building Address:** \_\_\_\_\_

3. **Name of Owner:** \_\_\_\_\_

Mailing Address: \_\_\_\_\_

**Phone No.(s):** Home: \_\_\_\_\_ Work: \_\_\_\_\_ Cell: \_\_\_\_\_

3. **Name of Contractor:** \_\_\_\_\_

**Mailing Address:** \_\_\_\_\_

**Phone No.(s):** Office: \_\_\_\_\_ Cell: \_\_\_\_\_ Contact: \_\_\_\_\_

4. Lot Area: \_\_\_\_\_ Percentage of lot to be occupied: \_\_\_\_\_ %

5. Lot Width: \_\_\_\_\_ Lot Depth: \_\_\_\_\_

6. Yard Dimensions: Front: \_\_\_\_\_ Rear: \_\_\_\_\_

One Side: \_\_\_\_\_ Sum of Side Yards: \_\_\_\_\_

15. **Estimated Project Cost:** \_\_\_\_\_

**NOTE: This permit shall be void if work is not started within six (6) months or completed within 2 years.**

**Printed Name:** \_\_\_\_\_

**Signature:** \_\_\_\_\_

**Date:** \_\_\_\_\_

Applications may be submitted in person at the Permit office – 1219 Henry S Thibodaux Street, Thibodaux, LA 70301  
OR

Via email to [mreulet@ci.thibodaux.la.us](mailto:mreulet@ci.thibodaux.la.us) or [scabrera@ci.thibodaux.la.us](mailto:scabrera@ci.thibodaux.la.us)

**FENCE PERMIT APPLICATION**  
**Thibodaux, Louisiana**

Phone: (985) 446-7208

CHECKLIST:

- Permit Fee: \$23.00
- Completed Application
- Site Plan

**Property Address:** \_\_\_\_\_

**Owner Name:** \_\_\_\_\_

Mailing Address: \_\_\_\_\_

Phone Number: Home \_\_\_\_\_ Cell \_\_\_\_\_ Work \_\_\_\_\_

**Contractor Name:** \_\_\_\_\_

Mailing Address: \_\_\_\_\_

Phone Number: Home \_\_\_\_\_ Cell \_\_\_\_\_ Work \_\_\_\_\_

**Total Length of Fencing:** \_\_\_\_\_

**Estimated Cost of Project:** \_\_\_\_\_

\_\_\_\_\_  
**Applicant Printed Name**

\_\_\_\_\_  
**Date**

\_\_\_\_\_  
**Applicant Signature**





## City of Thibodaux

### Site Plan

#### Required Information:

- Lot(s) involved in project
  - Property lines
  - Outline of existing structure(s) on property with dimensions
  - Dimensions and outline of proposed project – new structure, fence, pool, etc
  - Distances between structures and from property lines
  - Driveways
  - Adjacent street(s)
- 

Applications may be submitted in person at the Permit office – 1219 Henry S Thibodaux Street, Thibodaux, LA 70301  
OR

Via email to [mreulet@ci.thibodaux.la.us](mailto:mreulet@ci.thibodaux.la.us) or [scabrera@ci.thibodaux.la.us](mailto:scabrera@ci.thibodaux.la.us)